



SPR 50

Operation manual

Tehnika 10
50104 Tartu, Estonia
+372 738 0594
+372 501 8519
www.spraytec.ee
info@spraytec.ee

The SPR 50 plaster spray unit (conveying pump) with a screw pump is designed primarily for pumping and spraying of plaster mixtures with a particle size of up to 6 mm. The device output can be adjusted with its variable-speed drive or by using pumps of different capacity. To properly disperse the material, the device must have compressed air at 400-800 l/min. and 3-6 bar. Using different spray guns, plaster can be applied to walls for smoothing and differently structured sprayed plaster surfaces can be made. The device can be also used to pump floor-levelling mixtures and vertical-joint mixtures.

Due to the simple construction of the plaster spray unit, its casing made from galvanised steel and the large rubber wheels the device is very reliable and can be conveniently moved around.

1. Technical data

Pump	2L6
Capacity	5-60 l/min
Pump pressure	max 25 bar
Speed of rotation	44-366 rpm
Power supply	5,5 kW 380V
Container volume	100 liters
Material hose	38 mm 20 m (max 60m)
Nozzles	10, 12, 14, 16 and 18 mm
Air requirement	400-800 l/min at 3-6 bar
Length	2200 mm
Height	730 mm
Width	690 mm
Weight	190 kg

2. Standard delivery

- spray unit SPR 50
- material hose 20 m, ID 38 mm
- air hose 20 m
- distance control unit
- standard gun
- nozzles 12, 14, 16, 18 mm
- cleaning balls 2 pcs
- operation instruction

3. Safety precautions

- 3.1 The device can only be operated by properly trained employees who have read the user manual.
- 3.2 During device operation no unauthorised persons are allowed near it.

- 3.3 It is forbidden to work without the container protection grid.
- 3.4 Place the device on a secure base.
- 3.5 Lay the material hose so that nothing is driven over it. Attach the vertical sections of the hose securely to the scaffolding.
- 3.6 Use correct electric cables and regularly check the electrical system to ensure it is functioning properly.
Maintenance and repairs of the device's electrical system can only be performed by an employee with the corresponding qualification.
- 3.7 Check the hose connections and proper functioning on a regular basis.
- 3.8 Prior to connecting the distance control unit cable to the device (view C, figure 2), move the distance switch to the OFF position (view A, figure 6) (the switch handle is directed towards the aperture in the switch casing) and turn the HAND-AUTO rotary switch on the electrical board (position 3, figure 3) to the neutral position.
- 3.9 Always disconnect the device from the electricity source before cleaning and performing maintenance.
- 3.10 In an emergency press the emergency stop button (position 8, figure 3).
- 3.11 Do not put your hand in the container when the device is in operation.
- 3.12 To clean the hoses, start by releasing pressure from them (see point 7.6).
- 3.13 If clogging occurs, proceed as described in point 7.6.
- 3.14 When cleaning the device with a high-pressure washer, cover the motor and the electrical board securely and do not direct the water jet towards the motor and the electrical board.
- 3.15 Do not direct the spray gun towards people.

4. Device preparation and work commencement

- 4.1 Place the device on a horizontal, level and clean surface.
- 4.2 Conduct a visual inspection of the device to make sure it is operational.
- 4.3 If possible, place the compressor in another room or at least as far as possible from the working area.
- 4.4 Lay the material hose so that nothing can damage it.
- 4.5 Attach the vertical section of the hose securely to the scaffolding.
- 4.6 Connect the compressor hose to the plaster spray unit's air hose.
- 4.7 Make sure that the switches on the device's electrical board are in their neutral position.
- 4.8 Connect the electric cable (5 x 2.5 mm², 32 A) to the plug in the device's electrical board (position 7, figure 3).
The white indicator lamp will go up on the electrical board (position 5, figure 3).
- 4.9 Pour into the device's container approximately 20 litres of a light solution of wallpaper glue.
- 4.10 Turn the HAND-AUTO control switch on the electrical board (position 3, figure 3) to the HAND position and the reversing switch to position 1 (position 6, figure 3). Start the device by pressing the green START button (position 1, figure 3). Pay attention to the direction of rotation of the cardan shaft (see figure 1). When you are standing behind the device and the cardan shaft is rotating clockwise, the pump is pumping, and when the cardan shaft is rotating counter-clockwise, the mixture is drawn from the hose into the container. To change the rotation direction, turn the reversing switch (position 6, figure 3) to position 2.
- 4.11 Make sure that the distance switch is in the OFF position. The handle of the switch in the OFF position is directed towards the aperture in the switch casing (view A, figure 6). Insert the device's distance cable plug into the socket in the device frame (view C, figure 2).
- 4.12 Turn the HAND-AUTO control switch on the electrical board (position 3, figure 3) to the AUTO position: the device can now be started with the distance switch.
- 4.13 Start the device and pump the wallpaper glue solution through the hose.
- 4.14 Adjust the device rotation to the minimum level. The variable-speed drive can only be adjusted when the device is on. To reduce the device speed (pump output), turn the variable-speed drive's hand wheel (view D, figure 2) counter-clockwise. To increase the pump output, turn variable-speed drive's hand wheel clockwise. Prior to adjusting the variable-speed drive, you must release the locking handle (locknut) (view D, figure 2). After adjustment you must tension the locking handle. Switch off the device.
- 4.15 Connect the spray gun to the hose. Make sure that the gun valves on the device are closed. To connect the standard gun, remove the coupling at the end of the hose (position 2, figure 6). Press the gun coupling (position 1, figure 4) into the hose.
Connect the texture gun to the coupling at the end of the hose. Connect the air hose. Put the spray gun nozzle on the spray gun.
- 4.16 Fill the container with the mixture. Stir the mixture in accordance with the manufacturer's

recommendations. Use only such mixtures that are designed for pumping. Monitor the mixture particle size so that it does not exceed the device manufacturer's stipulated limit. Stir the mixture to a somewhat more liquid state than when using the mixture for manual application.

4.17 Start the compressor.

4.18 To begin work, open first the air valve (position 9, figure 4, or position 7, figure 5), then the material valve (position 9, figure 5) and lastly start the device via the distance switch (position 5, figure 6). When the mixture begins emerging evenly from the spray gun, adjust the air pressure and the pump output (see point 4.14).

4.19 To adjust the standard gun's spraying intensity, you can move the gun's air pipe (position 5, figure 4) in relation to the spray gun nozzle's aperture (position 4, figure 4). The end of the air pipe must be at a distance of approximately 1 cm from the spray gun nozzle's surface on the inside. The spraying intensity can be adjusted by using different nozzles and regulating the compressed air pressure level.

4.20 To switch off the device, begin by stopping it with the distance switch, then wait for a few seconds and close the material valve, followed by the air valve.

4.21 When going away, shift the electrical board switched to their neutral positions and disconnect the device from the electricity source.

5. Device cleaning

5.1 Having finished work, clean the device immediately. You must take special care when working with rapidly solidifying mixtures.

5.2 Perform cleaning in the following manner:

- pump all remaining mixture out of the container;
- disconnect the device from the electricity source, remove the container protection grid (figure 1), pour water into the container and apply a brush to remove the remaining mixture from the container walls;
- disconnect the spray gun from the hose and clean it. When cleaning the standard gun, remove the air pipe (position 5, figure 4) and clean the nozzle separately. Prior to reconnecting the parts, apply a lubricant to the pipe surface.

When cleaning the texture gun, remove the nozzle (position 1, figure 5). Clean the nozzle's air ducts. Having cleaned the gun, apply a lubricant to the threads;

- connect the device to the electrical grid, add water to the container and pump it clean. Repeat if necessary. Remove the container outlet plug (figure 1) and clean the bottom of the container from any mixture still there;
- replace the container outlet plug. Disconnect the material hose from the device, insert the cleaning ball into the hose coupling (stator housing) (figure 1) and reconnect the hose to the device. Pour clean water into the container, switch on the device and engage the pump until the cleaning ball is discharged from the hose. Repeat until the ball is discharged from the hose with clean water;
- for cleaning the hose after certain mixture, compressed air can be used as well. Details are available from the pump seller;
- disconnect the device from the electricity source and clean the external surfaces of the device and hoses.

When cleaning with a high-pressure washer, cover securely the motor and the electrical board and do not direct the washer jet towards them;

- depending on the mixture, you must sometimes dismantle the stator housing (figure 1) and clean its internal surfaces.

5.3 When there is a risk of freezing, you must remove all water from the device.

6. Maintenance

6.1 The space behind the rubber plate (position 2, figure 7) that seal the reduction gear unit's driving shaft (position 5, figure 7) must be filled with a lubricant. The lubricant nipple (view F, figure 2) is situated on the flange of the device frame, under the electrical board. Use a lubricator to apply the lubricant until you see it discharging from between the driving shaft and the rubber plate (view E, figure 2). Lubrication must be performed on a daily basis. Use a waterproof lubricant.

6.2 Monitor the sealing rubber plate (position 2, figure 7) for depreciation. If water and mixture seep from the rubber plate, replace it.

6.3 Check the condition and attachments of all device parts.

6.4 When the pump pressure falls, you can tension the pump using the clamping jacket (view A, figure 2).

Tension the clamp bolts by half-turns. Avoid overtensioning because it will lead to rapid pump depreciation and hinder motor operation, too.

6.5 Remove the stator housing (position 31. figure 7) and clean its internal surfaces on a regular basis.

6.6 Conduct visual inspections of the device's cardan shaft and cardan joint (figure 1).

6.8 Keep clean the device casing, motor drive and electrical board. When cleaning the device with a high-pressure washer, cover securely the motor and electrical board. Do not direct the water jet towards them.

7. Recommendations

7.1 Select a suitable pump feeding speed. The smaller is the gun nozzle, the lower must be the pump's output. Output adjustment is described in point 4.14.

7.2 Always clean the device in a timely and careful manner.

7.3 Before starting work, treat the hoses with wallpaper glue or a putty solution.

7.4 If there is a risk of rubbish finding its way into the pump container, cover the container with film or cardboard.

7.5 When the pump gets stuck, try to operate the device by reversing the pumping direction. If possible, reduce the device operation speed. Remove the material hose but make sure first that it is not under pressure. If the motor cannot move the stuck pump, you must remove the pump and press out the rotor. Address the issue to the seller.

7.6 If a hose becomes clogged, you must stop the device immediately and reverse the pumping direction (see point 4.10). Re-start the device and withdraw the mixture from the hose back into the container. Stop the device and remove the hose. Find the clogged spot in the hose (hard spot). Bend and press the clogged spot until you feel that the mixture moving freely again. The hose cannot be tapped with metal objects. Raise the clogged spot and try to shake the mixture out of the hose.

A very effective way to eliminate clogging is to push the water hose into the material hose and wash away the clogged material.

With the clogging problem solved, reconnect the hose to the device and try the pump. Repeat the actions described above if necessary.

7.7 Lubricate on a daily basis the rubber plate of the driving shaft.

7.8 Clean and lubricate the clamping jacket and the stator housing bolts, too.

7.9 Lubricate the spray gun threads and the air pipe of the standard gun.

7.10 Protect the pump from freezing. Store the device in a heated room or remove from the unused device's container, pump and hoses any water still remaining in them.

8. Malfunctions and solutions

Malfunction	Cause	Solution
The device is new but the motor cannot drive the pump	The new pump is dense and after being unused for a while the rotor can become adhered to the stator	Pour water into the container. Try to operate the device in both directions. If necessary, remove the pump and try to shift the rotor. Pump rotation is facilitated by application of a lubricating liquid
When the device is switched on, the pump does not rotate while the motor is droning	Check the device's voltage The pump is stuck	Only a qualified electrician can perform electrical repairs Release the clamping jacket bolts and clean the pump
The electric motor is working but the cardan shaft is not rotating	The variable-speed drive's belt is ruptured	Contact the device seller
It is difficult to close the device's hose connections	Some mixture has seeped into the connecting parts	Clean the connecting parts
Mixture is dripping down from the device	The rubber plate of the driving shaft is depreciated	Contact the device seller. Replace the depreciated rubber plate

The pump is working but there is no mixture discharge from the spray gun	The spray gun or its nozzle is clogged The hose is clogged	Stop the device. Operate it in the reverse mode. Remove the gun and clean it Solution described in point 7.6
The device is not switched on via the distance switch	The distance control unit cable is not plugged in The control switch on the electrical board is not in the AUTO position Faulty distance switch or cable	Plug in the cable (view C, figure 2) Turn the switch to the AUTO position Find the damage and eliminate it
The pump is working but the necessary pressure is not achieved	Depreciated pump	Tension the pump's clamping jacket. If tensioning does not produce the desired effect, replace the pump's rotor and stator

Warranty

The producer warrants equipment manufactured by it to be free from defects in material and workmanship on the date of sale. The producer will for the period of twelve month from the date of sale repair or replace any part of the equipment proven defective. This warranty applies only when the equipment is installed, operated and maintained in accordance with the operation manual.

This warranty does not apply:

- damages or wear caused by abrasion:
 - nozzles, rotor, stator;
- damages caused by misuse, accident or negligence during the operation the equipment (foreign substance has fallen into container);
- damage caused by faulty installation of the equipment;
- damage caused by operating the frozen equipment;
- damage caused by the pump that has not been cleaned;
- other malfunctions caused by the user ignoring the requirements stated in this operation manual.

Date of sale

Serial no

FIGURE 1

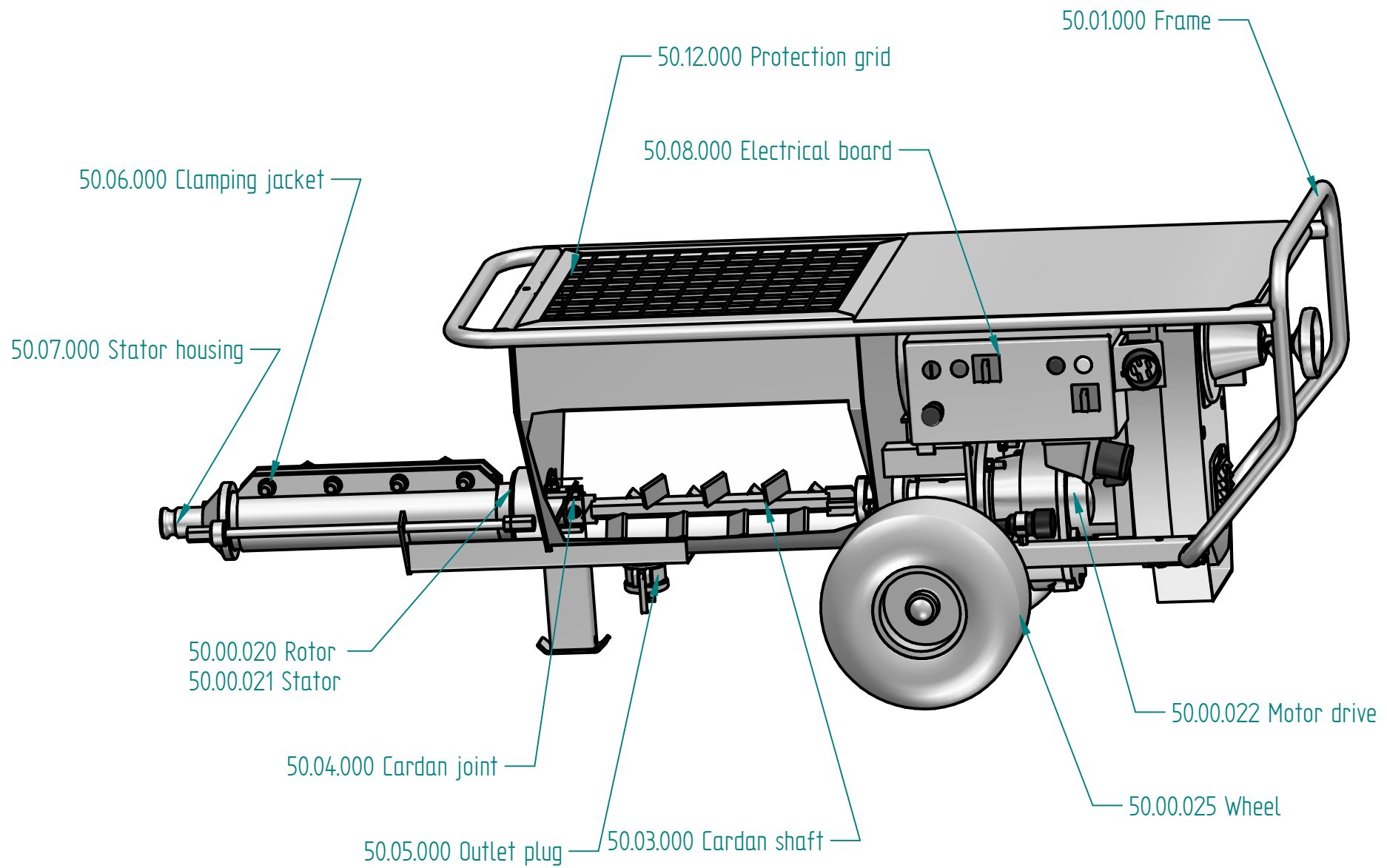
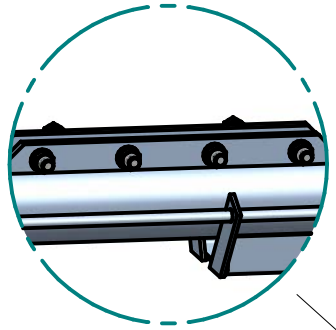

FIGURE 2



View A



View F

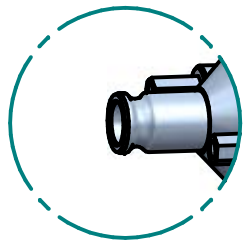
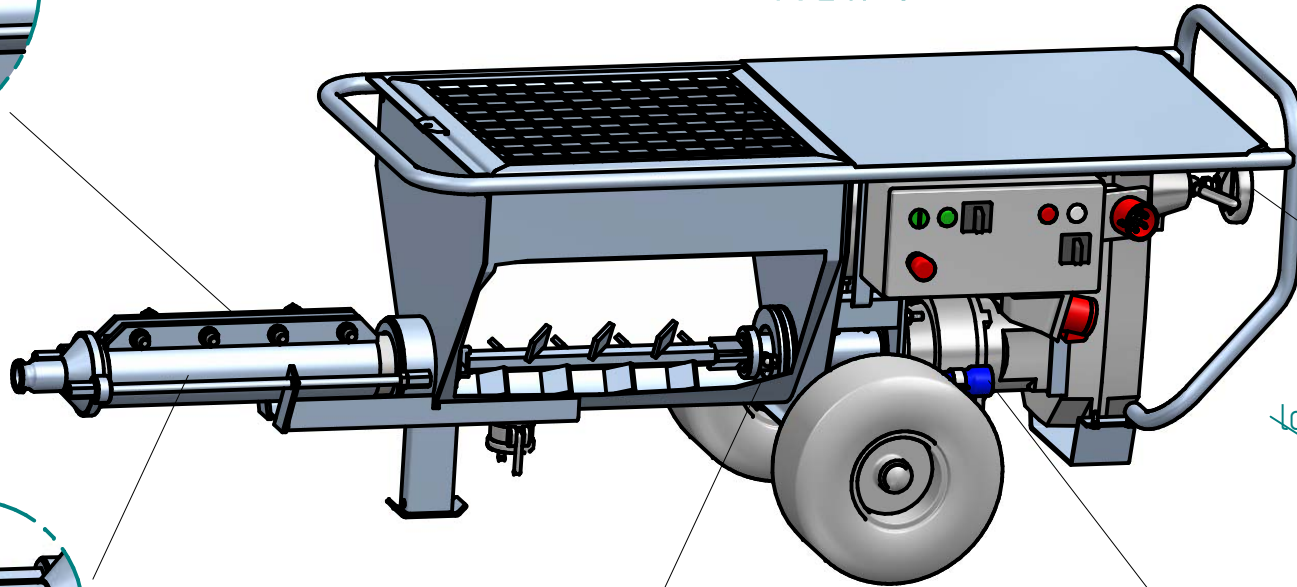

View B

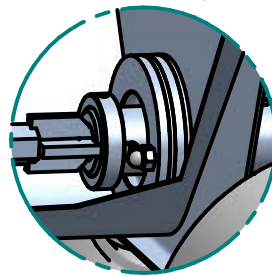

View E

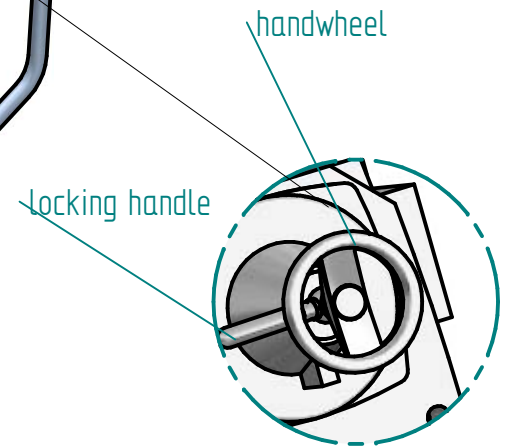

View D

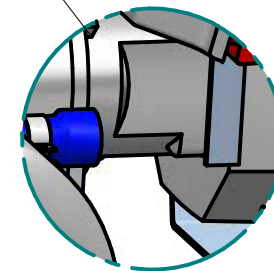

View C

FIGURE 3

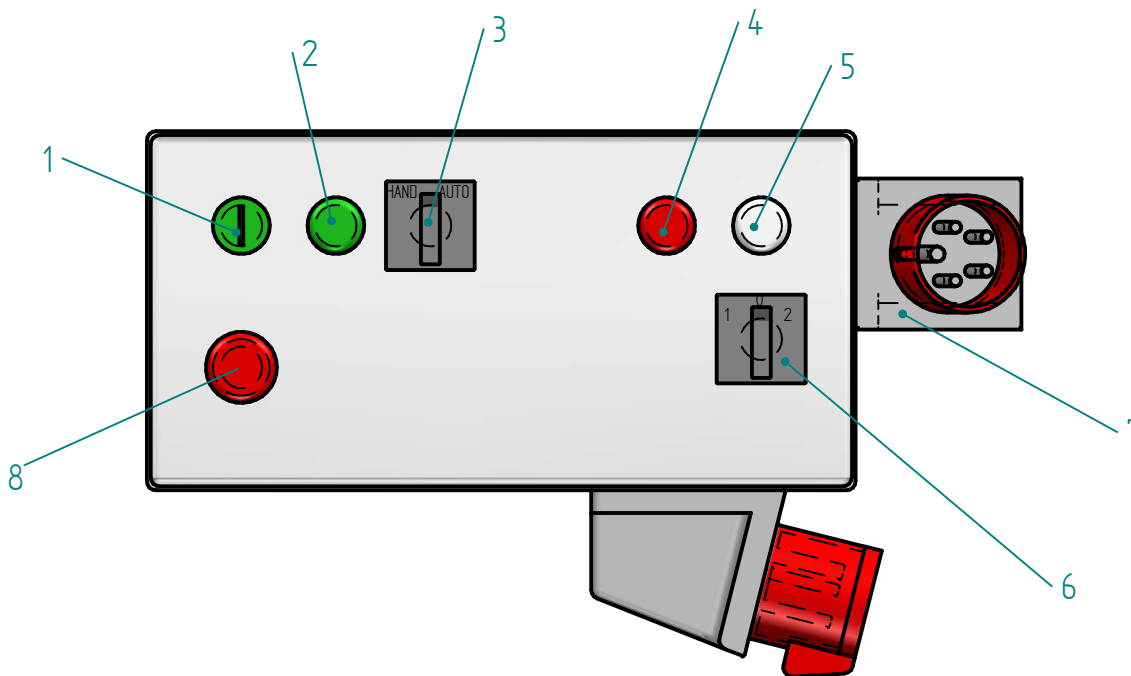

Pos.	Name
1	green START button
2	green indicator lamp
3	HAND-AUTO control switch
4	red indicator lamp
5	white indicator lamp
6	reversing switch
7	plug
8	emergency STOP button

FIGURE 4

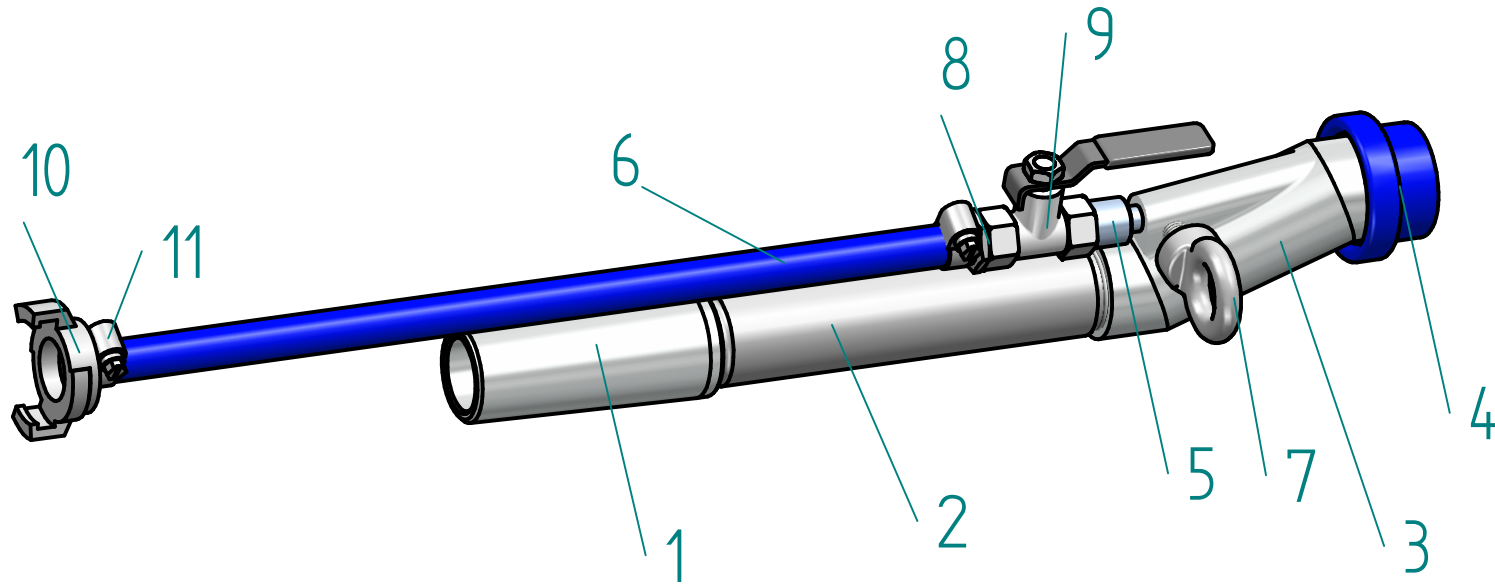

Standard gun 50.10.000

Pos.	Det. nr.	Name
1	50.10.001	couplin
2	50.10.002	tube
3	50.10.003	spray gun head
4	50.10.004	spray gun nozzle
5	50.10.005	air pipe
6	A22.440	air hose
7	50.10.007	eye bolt
8	A22.404	coupling 1/4"
9	A22.430	air valve
10	A22.090.015	brass coupling
11	A22.507	clamp

Texture gun RV 50.15.000

FIGURE 5

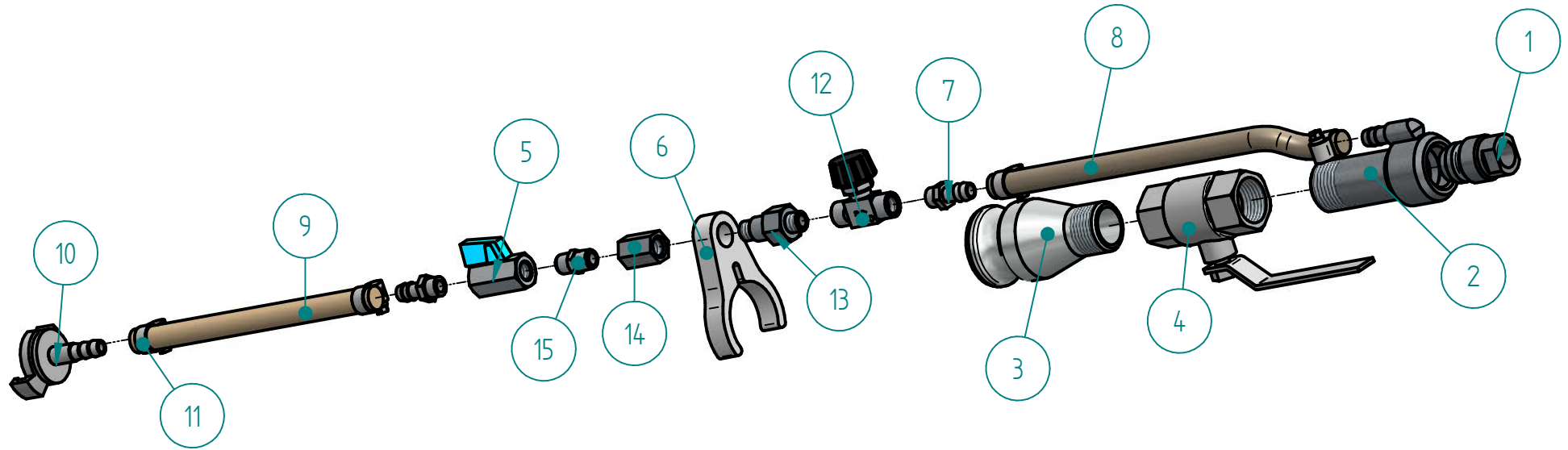

Pos.	Det. nr.	Name
1	50.15.001	Nozzle
2	50.15.100	Gun body
3	50.15.002	Hose connector G 1" 1/2"
4	50.15.003	Valve
5	A22.430	Valve 1/4"
6	50.15.005	Hose holder
7	A22.404	Connection 1/4" – 10 mm
8	50.15.007	Air hose front
9	50.15.008	Air hose back
10	A22.090.015	Connection 10 mm
11	A22.507	Clamp
12	A22.450	Air regulator
13	50.15.009	Air coupling
14	50.15.010	Bushing 1/4"
15	50.15.011	Coupling 1/4"

FIGURE 6

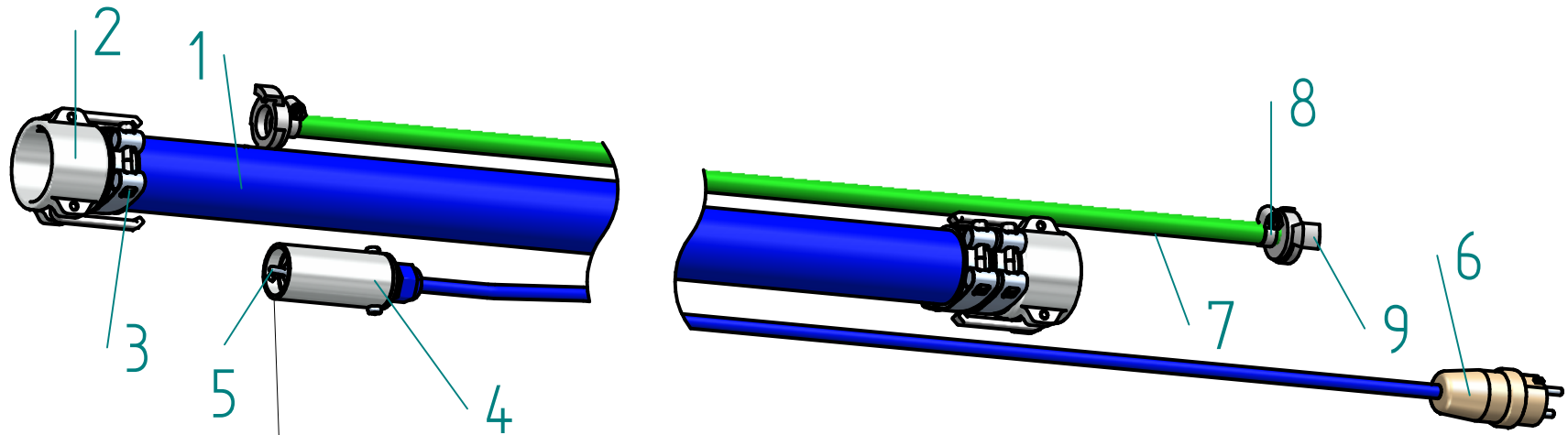

Hose 50.09.000
Distance control A22.600

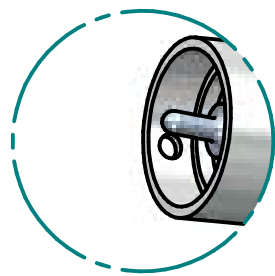

View A

Pos.	Det. nr.	Name
1	50.09.001	material hose ID38
2	50.09.002.	coupling CAM-AL-C-38
3	50.09.005	clamp
4	A22.600	distance control unit
5	A22.610	distance switch
6	A22.630	plug
7	A22.505	air hose
8	A22.507	clamp
9	A22.090.015	brass coupling

FIGURE 7

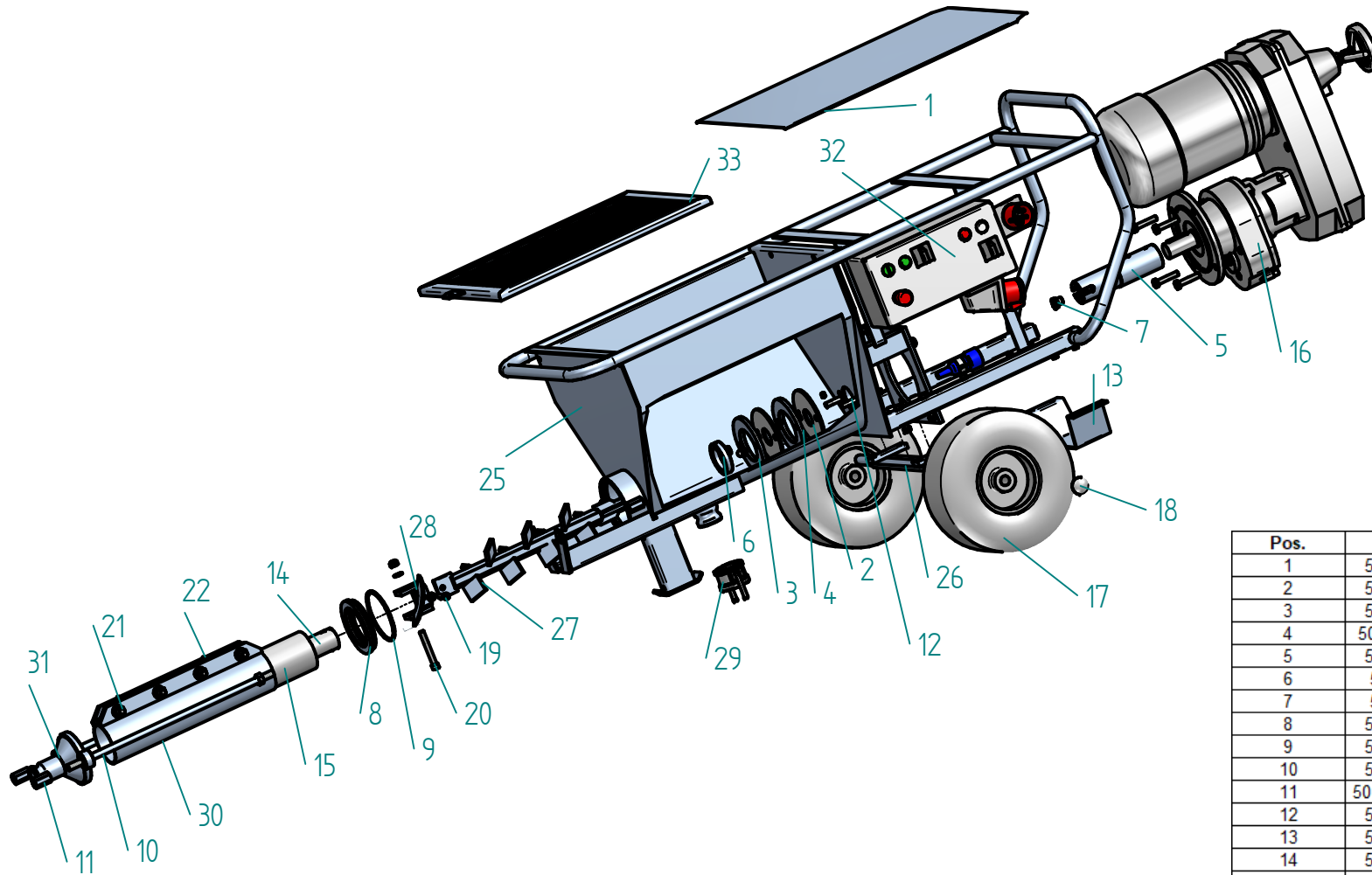

Pos.	Det. nr.	Name
1	50.00.001	guard plate
2	50.00.002	rubber plate
3	50.00.003	pressure plate
4	50.00.003-1	pressure plate
5	50.00.004	driven shaft
6	50.00.006	fixing ring
7	50.00.007	support
8	50.00.008	holding plate
9	50.00.009	O-ring
10	50.00.010	stud
11	50.00.010-01	nut
12	50.00.012	stud
13	50.00.013	guard plate
14	50.00.020	rotor
15	50.00.021	stator
16	50.00.022	motor drive
17	50.00.025	wheel
18	10601	fixing
19	50.00.027	bolt
20	50.00.028	bolt
21	50.00.029	tightening bolt
22	50.00.030	bolt
25	50.01.000	frame
26	50.02.000	wheel axel
27	50.03.000	cardan shaft
28	50.04.000	cardan joint
29	50.05.000	outlet plug
30	50.06.000	clamping jacket
31	50.07.000	stator housing
32	50.08.000	electrical board
33	50.12.000	protection grid

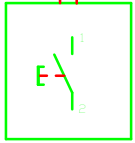
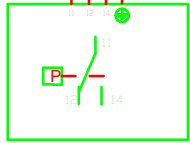
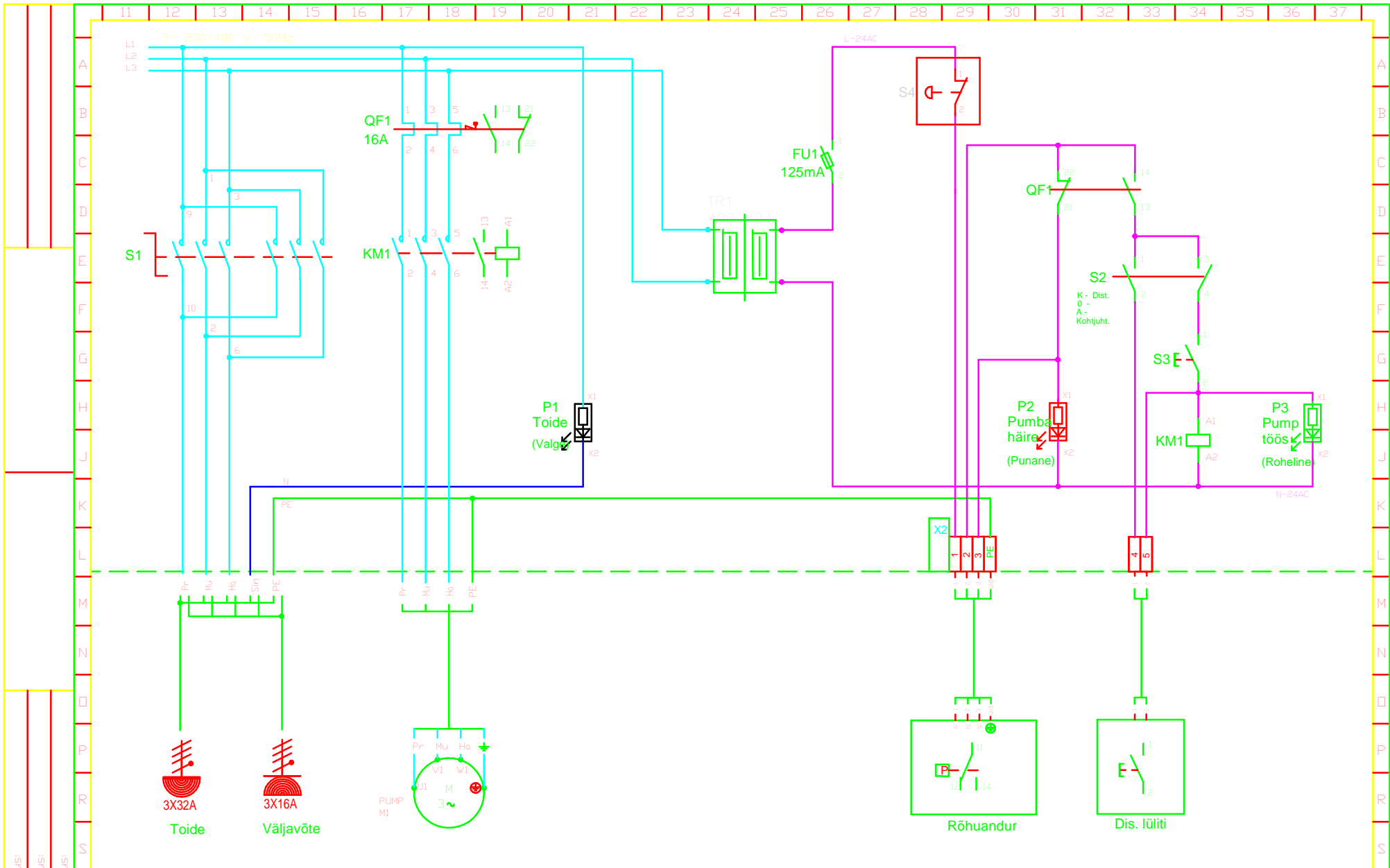

A. Muudatus:
B. Muudatus:
C. Muudatus:



Tellijä: SPRAYTEC OÜ
 Aadres: ROPKA TEE 22 TARTU
 Projekt: SPRAYTEC OÜ PAHTLIPRITS

SPR - 50

Projekteenis: Tõnu Kalljõe	Ahela nr. Leht 1/2	Keskuse nr. Joonise nr.	Töö nr. 00707-EA
Kontrollis: Larvo Klaas			00707-EA
Kuupäev: 13.10.2011.a			