

HEMO 10

Operation manual

Tehnika 10
50104 Tartu, Estonia
+372 738 0594
+372 501 8519
www.spraytec.ee
info@spraytec.ee

Spray unit HEMO 10 is an airless high-pressure device for spraying of putty, viscous paints, glues and other liquids during construction finishing work. The particle size in the sprayed substance cannot exceed 0.6 mm. The device can be used to spray both ready-mixed putty and putty mixed on-site from powder. The spray unit includes a bag wringer for emptying of ready-made putty bags.

I. SAFETY REQUIREMENTS

1. You must read the user manual prior to putting the device into operation.
2. Only a properly trained operator can use the device. Contact the company that sold you the device for information about terms and conditions of such training.
3. Only a properly trained specialist can perform maintenance of the electrical system of this device.
4. When the device is in operation, no irrelevant persons must be allowed near it.
5. The device must be operated in compliance with all requirements listed in this user manual.
6. During operation of the device the employees using it must precisely agree on the division of their functions.
7. If the device is not in the same room as the spraying operator, (s)he must be notified about container filling and other actions performed with the device.
8. Only materials specified for the purpose can be used for spraying. If necessary, address your questions to the material manufacturer.
9. Means of protection (goggles, gloves, proper work clothing) must be used when operating the device.
10. Never point the spray gun at people!
11. Having completed the work, release pressure from the hose and the spray gun (see DEVICE START-UP, point 9) and lock the spray gun trigger. Do not leave the pressurised device unsupervised!
12. If the spray tip of the gun becomes clogged, follow the instructions in the user manual (see RECOMMENDATIONS, point 9).
13. Prior to putting the device into operation make sure that its hose, spray gun, tip and other parts are securely attached.

14. The device can only be connected to the electrical grid using such components that comply with the manufacturer's technical specifications. If different standards are in use, please contact the product seller.
15. The device is equipped with an emergency STOP switch (see Figure 2 in Passport 1). Engagement of the switch discontinues the device operation. Disconnect the device from the electrical grid when performing maintenance and repairs! Do not engage the emergency STOP switch – you must remove the power cable from the grid socket!
16. For the duration of the device maintenance and repairs you must release pressure from the hose and the pump (see DEVICE START-UP, point 9).
17. Put the cover on the device container to prevent external items from falling into the container.
18. Clean the device in due time!
19. Perform device maintenance and repairs in accordance with the recommendations listed in the user manual. Address any questions you may have to the seller company.
20. Prior to performing maintenance of the hydraulic system be sure to release pressure from the system (see DEVICE MAINTENANCE, point 2).
21. When repairing the device, use original spare parts to ensure safe device operation and preserve its warranty.
22. Have the seller company take care of larger-scale repairs.

II. TECHNICAL DATA

Motor	3 kW
Electrical requirement	380 V/50 Hz, 3 phases
Capacity	12 l/ min
Fuse	16 A
Pump	3 hardened steel pistons
Max pump pressure	110-150 bar
Container volume	75 liters
Length	1430 mm
Height	900 mm (1030 mm incl. bag emptier)
Width	650 mm
Weight	150 kg
Length of hose	10 m 1/2" or 18 m 5/8"
Nozzles	651, 661, 663 (max 695)

III. STANDARD DELIVERY

1. Spray unit
2. Hose 10 m 1/2"
3. Spray gun SP 25.000
4. Spray tip 661
5. Bag wringer
6. Container cover
7. Repairing kit
 - support ring 10115 3 pcs
 - valve ball 10126 3 pcs
 - valve spring 10127 3 pcs
 - collar sealing 10246 3 pcs
 - filling tool 10466 1 pce
8. Operation manual

IV. ACCESSORIES

Nozzles (651, 663)
Hose 5/8" 18 m
Electrical cable 5 x 2,5 mm² 15 m

V. DEVICE DESCRIPTION (Figure 1)

The device chassis is made of stainless steel. The bag wringer, the chain wheel protector, the nose and the container cover are made of fiberglass material. These materials ensure long-term device durability. The device has large wheels with air-filled tyres and a handle for convenient relocation. All wrenches needed for device maintenance are attached to it.

These are the main components of the spray unit: pump, power transmission, hydraulic system, electrical unit, hose with gun and bag wringer.

The pump consists of three of piston cylinders, three ball valves, a pressure vessel and a filter. The pump applies pressure to the material to be sprayed.

The hydraulic system consists of a hand pump, a pressure gauge, hydrocylinders, a hydraulic accumulator and connection hoses. The hydraulic system protects the device from damage and enables slight adjustment of the sprayed material pressure. The oil pressure in the hydraulic system can be raised with the hand pump and reduced by opening the valve on the pump. When in operation, the hydraulic system pressure must be in the range of 110-150 bar.

The power transmission consists of an electric motor, a chain transmission, a crankshaft and rockers. The power transmission transfers power from the electric motor to the pump pistons. The electrical system consists of an electrical unit and pressure sensor. The device will start automatically when you press down the spray gun trigger. The pump will stop as soon as you release the trigger.

The bag wringer is for emptying of ready-mixed putty bags.

The device has a hose and a gun. The device hose must be able to withstand pressure of up to 150 bar.

VI. DEVICE START-UP

1. Place the device on a solidly even and horizontal surface. Avoid placing the device directly in the spraying area, but the device must be visible to the operator.
2. Make sure that the container is empty and clean.
3. Check the oil pressure in the hydraulic system: the pressure gauge (see Figure 3 in Passport 1) must indicate the pressure in the range of 110-150 bar (see DEVICE MAINTENANCE, point 2).
4. Make sure that the hose and the gun are securely connected. Put the necessary tip on the gun. Select the tip in accordance with the requirements of the material manufacturer.
5. Connect the power cable. The line protection must be 16 A.
6. Fill the container with the material. If you are using a dry putty powder, it must be thoroughly mixed with water in compliance with the putty manufacturer's instructions. Use a mixer. If you are using ready-mixed putty in a plastic bag, proceed in the following manner:
 - o Turn the bag wringer's roller to the rear position (see Figure 9 in Passport 1).
 - o Place the putty bag on the wringer, with the bottom towards the roller.
 - o Turn the roller so as to capture the end of the bag.
 - o Holding with one hand the bag handle, cut the bag open as closely as possible to the handle end.
 - o Wring the bag empty.
 - o Make sure that no bag bits fall into the container.
 - o Turn the roller back into the rear position.
 - o Remove the empty bag and, if necessary, clean the wringer edge from any putty.
7. The device is ready for operation. Holding with one hand the closed spray gun, press the START button on the electrical unit (see Figure 2 in Passport 1). The device will start and the material pressure in the pump and in the hose will rise until the pressure sensor induces stoppage. Now you can begin spraying. The device will start when you press the gun trigger (see Figure 6 in Passport 1) and stop when you release the trigger.
8. If the device is functioning abruptly, adjust the pressure sensor. Turn the pressure sensor knob (see Figure 2 in Passport 1) clockwise until the device is functioning smoothly. If the device does not stop after you release the spray gun trigger, turn the pressure sensor knob counter-clockwise until the device stops. Check the regulation several times. When changing the material used for spraying and during oil pressure modification you might need to adjust the pressure sensor. Having made the adjustment, tighten the locknut.
9. Having completed your work, press the STOP button on the electrical unit (see Figure 2 in Passport 1). Press the gun trigger to release pressure. Even when you stop the work for a short while, be sure to release pressure from the system. When the work is done, engage the trigger lock (see Figure 6 in Passport 1).

10. Put the gun in a safe place.
11. In an emergency situation press the EMERGENCY STOP switch on the electrical unit (see Figure 2 in Passport 1) and the device will stop.

VII. DEVICE CLEANING

1. The device needs daily maintenance and cleaning. Having completed your work, do the following:
 - o Remove the spray tip and its holder and clean them with a brush.
 - o Pump all remaining material out of the device container. Switch off the device and disconnect it from the electrical grid.
 - o Pour clean water into the container and wash its walls with a fine or large brush or a jet of water.
 - o Connect the device to the electrical grid, switch it on and pump the container empty. If necessary, clean the inside of the container again.
 - o Disconnect the device from the electrical grid.
2. To clean the pump, follow the instruction in the PUMP DISASSEMBLY section.
3. When spraying rapidly hardening mixtures, be sure to clean the device as soon as you finish the work. When using mixtures that do not harden in water, it is sufficient to pour some water on top of the material in the container and cover it with plastic film.
4. You should thoroughly clean the device every time before you change the material. If the device is to be left unused for a longer period of time, it would be useful to lubricate the pump parts with oil.

VIII. PUMP DISASSEMBLY (see Figure 4 in Passport 1)

1. You must disassemble the pump before you can clean and repair it. For pump maintenance you will need the three wrenches attached to the device chassis (see Figure 8 in Passport 1), a cleaning brush and water. You can also use a pressure washer to clean the inside of the pump.
2. Disconnect the device from the electrical grid.
3. Press the spray gun trigger to release any material residue under pressure from the hose.
4. Screw out the pump bottom plug (item 1 in Figure 4) using the wrench (Figure 8, Passport 1). Be careful when screwing out the bottom plug because there can still be some residual pressure in the pump. In the bottom plug screw thread is a channel for material under pressure to exit the pump prior to plug removal.
5. Screw out the nut of the tension ring (item 13 in Figure 4) using the wrench, open the tension ring and remove it.
6. Screw the dismantling wrench (Figure 8, Passport 1) into the bottom plughole. As you turn the wrench, the pressure vessel will become detached (item 3 in Figure 4).
7. Use the wrench to screw out the pump holding bolt (item 4 in Figure 4), remove the filter clip (item 5 in Figure 4), the filter itself (item 6 in Figure 4) and the filter holder (item 7 in Figure 4).
8. To disassemble the filter, press the lugs on the inside of the filter holder and pull the filter

holder out of the clip. Remove the filter.

9. Screw out the distance bolts (item 8 in Figure 4) and remove the valve base (item 9 in Figure 4).
10. Take the support rings (item 10 in Figure 4) and the collar sealings (item 11 in Figure 4) out of their seats.
11. Open the ball valves by screwing out the parts (item 17 in Figure 4). Remove the springs (item 16 in Figure 4) and the balls (item 15 in Figure 4).
12. Wash all parts and check their condition. For convenient washing of the pressure vessel you can remove the material and pressure sensor hoses. There are channels in the screw threads of the bottom plug, distance bolts, holding bolt and assembling wrench and you must clean these channels. Do not perform cleaning with sharp metal objects, you must use sturdy brushes.
13. To determine the condition of the collar sealings, examine the working edge of the sealing: it must be intact. Replace the sealings if necessary. To determine the condition of the ball valves, check the balls and make sure they have no damage. Pay attention to the valve seats. Replace with new parts if necessary.
14. Assemble the pump in the opposite sequence. Treat all screw threads with a lubricant to ensure that you can easily disassemble the pump next time.
15. Screw the ball valves back in manually, do not tighten them with a wrench.
16. Install the collar sealings (item 11 in Figure 4) so that the smooth side of the sealing is towards the support ring (item 10 in Figure 4).
17. When installing the filter unit, make sure that the lugs in the filter holder remain between the ball valves.
18. Use the assembling wrench to install the pressure vessel (see Figure 8, Passport 1). Put the pressure vessel in its place, insert the assembling wrench into the bottom plughole and turn it. The pressure vessel will be pressed against the valve base. Install the tension ring. The span between the ringsides prior to bolt-tightening must be approximately 5 mm. If the interval is larger you must shift the ring back and forth until it fits its place. Install the connecting bolt and tighten the nut. Remove the assembling wrench.
19. Install the bottom plug. Clean the wrenches and put them in their places.

IX. DEVICE MAINTENANCE

Daily maintenance prior to work commencement.

1. Check that the electrical devices (cable, connectors, electrical unit buttons) are in proper working order.
2. The oil pressure in the hydraulic system must be in the range of 110-150 bar. If necessary, raise the pressure level by operating the hand pump. To reduce the pressure level, open the pressure release valve on the hand pump (see Figure 3, Passport 1).
3. Make sure that the gun, the hose and the tip are attached securely.
4. During the visual inspection make sure that all units in the device are in proper working order.

The pressure in the device tyres must be 2 - 2.5 bar and equal on both sides.

5. Prior to pouring the mixture into the container make sure that the container is clean.

X. OTHER MAINTENANCE WORK

1. Check the oil level in the hand pump. Remove the rubber plug from the rear end of the pump. The pump oil tank must be at least half-full. If necessary, add hydraulic oil (HLP 46).
2. The pressure sensor hose (see Figure 2, Passport 1) must be filled with a lubricant. To check the hose, remove it from the device. Prior to removing the hose, make sure that the device is disconnected from the electrical grid and the residual pressure has been released from the pump (see PUMP DISASSEMBLY, points 3 and 4). Screw the included filling tool into the electrical-unit end of the removed pressure sensor hose. Connect the grease gun to the filling tool and pump the lubricant into the hose. Keep pumping until the clean lubricant comes out of the other end of the hose. Use a waterproof lubricant. Clean the pressure vessel pressure sensor hose connection and fill it with the lubricant. Install the pressure sensor hose.
3. Check the tension of the motor chain once per year. Remove the chain wheel protector (see Figure 1, Passport 1). Unloose the motor fastening bolts. The motor will move down due to its weight and tension the chain. Tighten the bolts. Apply a special chain lubricant to the chain. Install the chain wheel protector.
4. To check that the hydraulic system parts are in proper working order, remove the nose (see Figure 1, Passport 1). Conduct a visual inspection of the hydraulic system. If you discover an oil leak, contact the seller company.

XI. RECOMMENDATIONS

1. Always select suitable spraying materials. Follow the material manufacturer's recommendations.
2. Place the special cover on the device container, or at least a layer of plastic film or cardboard, to prevent rubbish falling into the container.
3. Clean the putty bag before placing it on the bag wringer. Immediately after emptying the bag you must clean the wringer and the roller surface.
4. Always adjust the pressure sensor (see DEVICE START-UP, point 8).
5. You must also clean the motor chassis to prevent motor overheating.
6. Store the device in a room where the temperature never falls below zero degrees. If the device is likely to be exposed to cold conditions, clean the inside and dry it. Remove the hose and the gun and blow them dry using compressed air.
7. Do not remove excess putty from the processed wall and put it back into the device container. Be especially careful when spraying the first layer. Do not clean the spatula by rubbing it against the container edge.
8. When moving the device, it is not recommended to store the hose in the container because rubbish from the hose surface can fall into the container.
9. If the spray tip becomes clogged, release the gun trigger and turn the tip 180 degrees (anti-

clockwise). Press the trigger for a second. The device will start up, some of the material will flow through the tip, flushing it. Turn the tip back into the working position (clockwise). If turning the tip is difficult, you must release pressure from the hose (see PUMP DISASSEMBLY, points 1, 2, 3, 4).

XII. MALFUNCTIONS

You should contact the seller company about malfunctions.

MALFUNCTION	CAUSE	SOLUTION
The device cannot be switched on.	1. Problem in the electrical system.	<ul style="list-style-type: none"> o Check all cables and connections. The line protection must be at 16 A. o If the red lamp is on in the electrical unit, the device thermal protection has become activated. The thermal protection will deactivate itself when the cause is removed. The thermal protection activation may have been caused by unequal power supply current phases or a poor connection in a cable or the electrical unit of the device. The device must be checked by an electrician.
	2. Either the gun or the tip is clogged.	<ul style="list-style-type: none"> o Clean the gun/tip (see RECOMMENDATIONS, point 9).
The device is switched on but does not stop when the gun trigger is released.	1. The pressure sensor hose is clogged.	<ul style="list-style-type: none"> o Clean the hose and fill it with the lubricant (see OTHER MAINTENANCE WORK, point 2).
The device is not working smoothly.	1. The pressure sensor needs adjusting.	<ul style="list-style-type: none"> o Adjust it (see DEVICE START-UP, point 8).
The device is not spraying smoothly.	1. The pressure sensor needs adjusting.	<ul style="list-style-type: none"> o Adjust it (see DEVICE START-UP, point 8).
	2. The pump pistons or sealings are worn out.	<ul style="list-style-type: none"> o Replace the parts (see PUMP DISASSEMBLY).
	3. The tip is worn out or broken.	<ul style="list-style-type: none"> o Replace the tip.
	4. The tip is too large.	<ul style="list-style-type: none"> o Replace the tip.
	5. The sprayed material is not suitable for use with this pump.	<ul style="list-style-type: none"> o Change the material, contact the material manufacturer.
The device is working but the pressure is insufficient.	1. Low pressure in the hydraulic system.	<ul style="list-style-type: none"> o Raise the pressure level. The operational pressure range is 110-150 bar. (See DEVICE START-UP, point 3).
	2. A ball valve ball is open or	<ul style="list-style-type: none"> o Check the pump parts (see PUMP

	worn out.	DISASSEMBLY).
	3. The tip is too large.	o Replace the tip.
	4. The hose is too long.	o Install a shorter hose.
	5. The pump pistons or sealings are worn out.	o Replace the parts (see PUMP DISASSEMBLY).

XIII. WARRANTY TERMS AND CONDITIONS

The manufacturer-provided warranty period is one year from the sale date.

The warranty covers technical malfunctions caused by manufacturing errors. The warranty does not cover:

- parts susceptible to abrasive depreciation during operation:
 - tips, hoses;
 - details: 10114, 10115, 10126, 10127, 10246;
- mechanical ruptures;
- damage caused by items that fell into the container;
- malfunctions caused by the pump that has not been cleaned;
- damage from cold;
- other malfunctions caused by the user ignoring the requirements stated in this manual.

Device number:

Sale date:

FIGURE 1 (Passport 1)

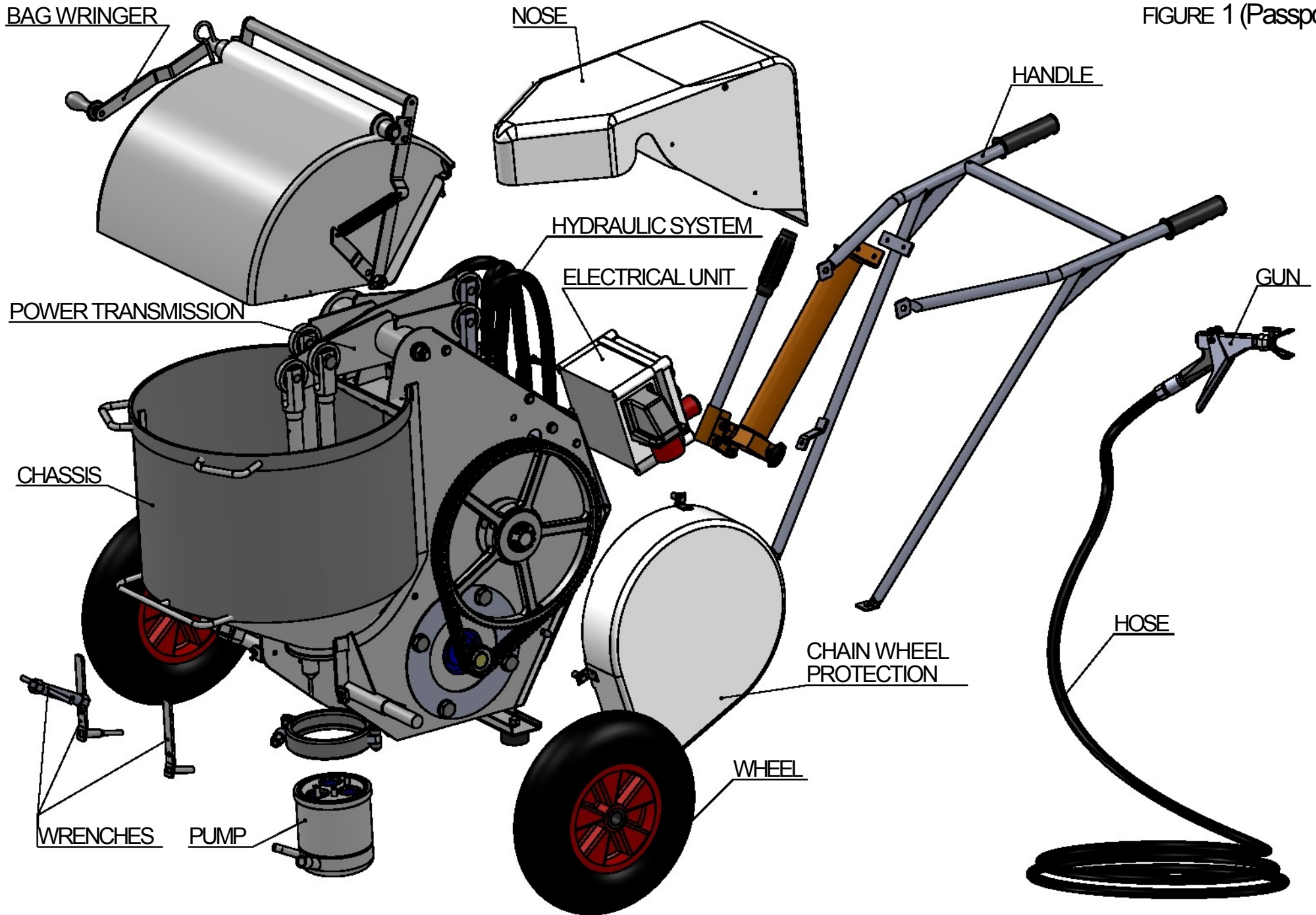

FIGURE 2 (Passport I)

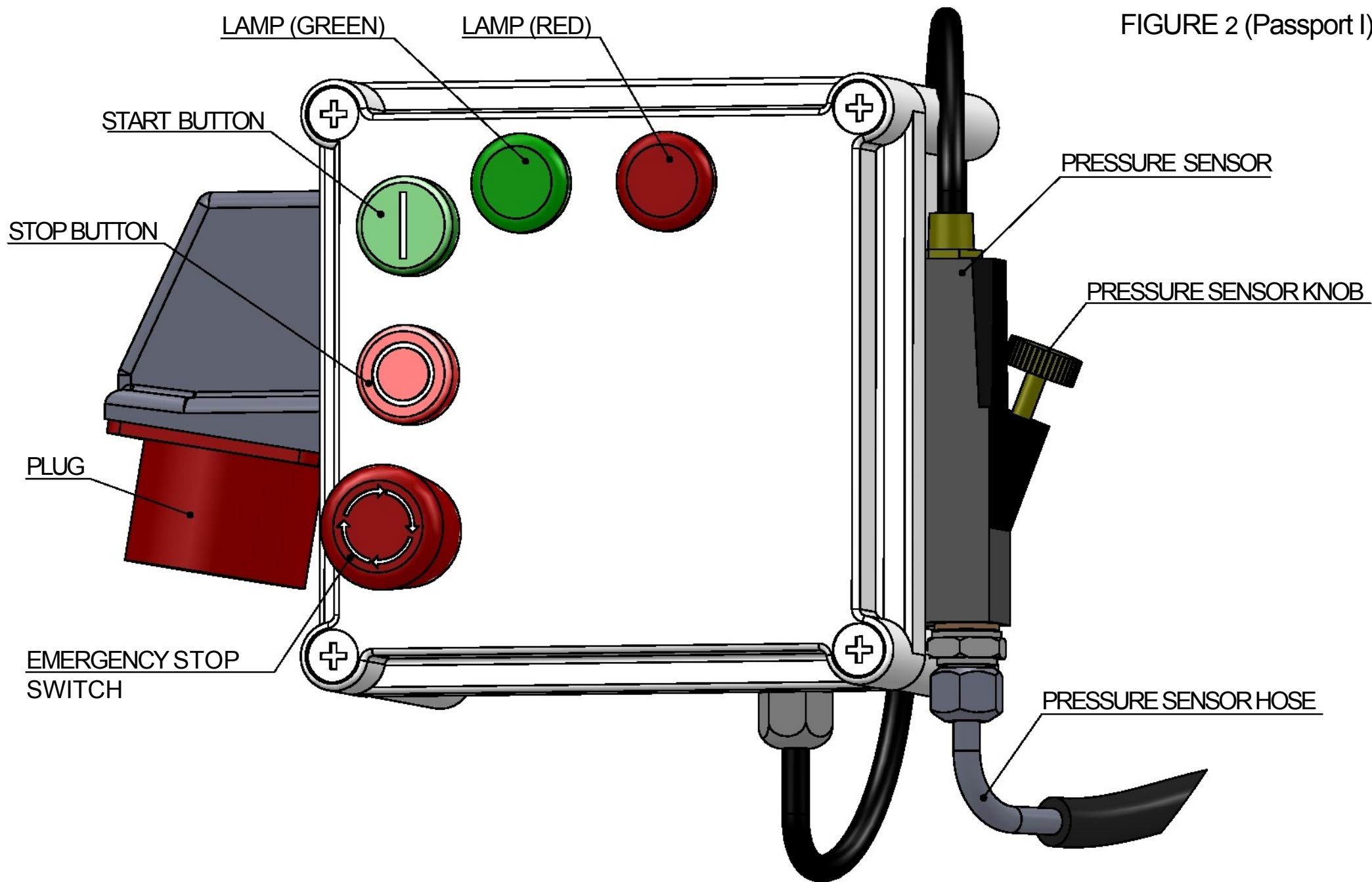

FIGURE 3 (Passport I)

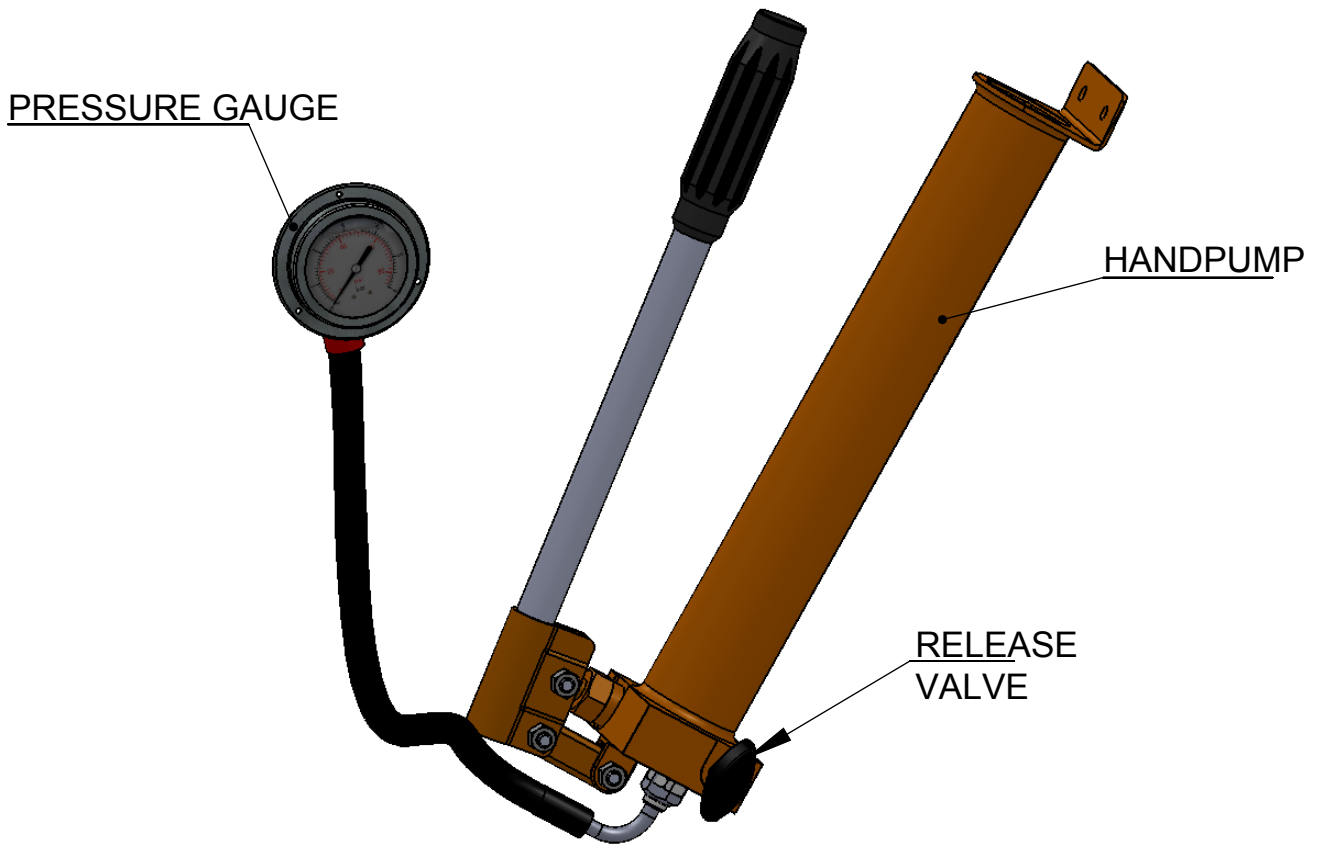

FIGURE 6 (Passport I)

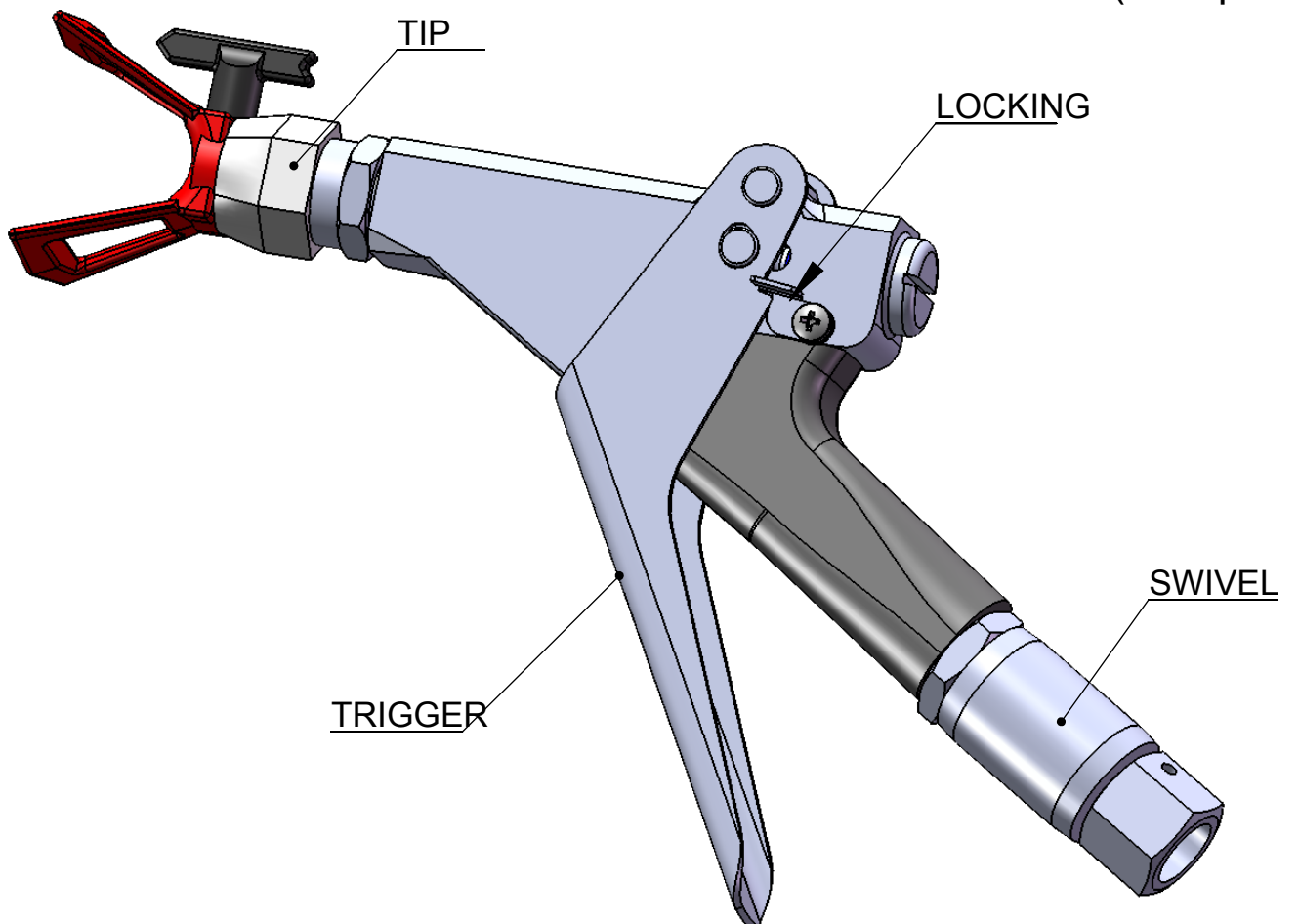
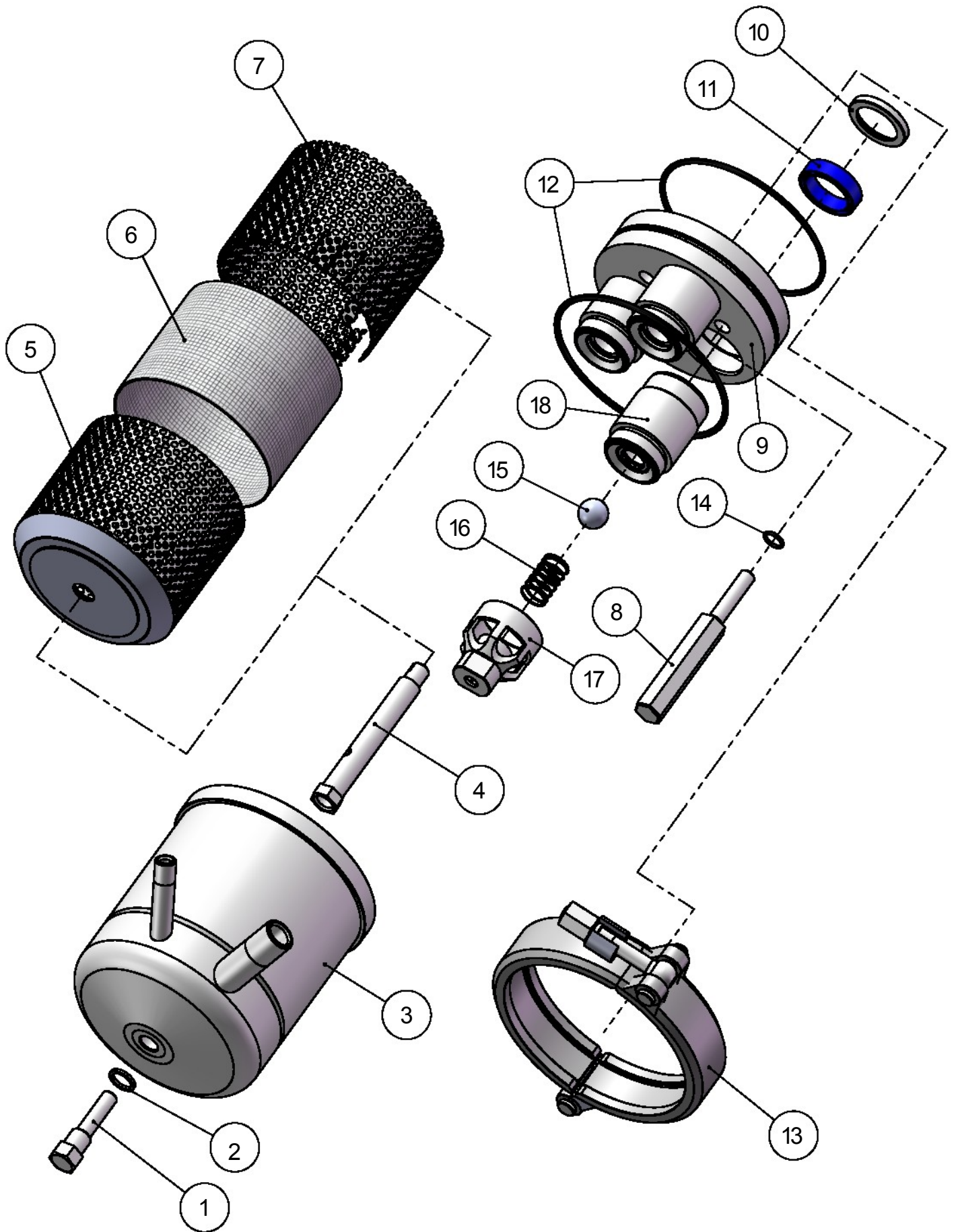
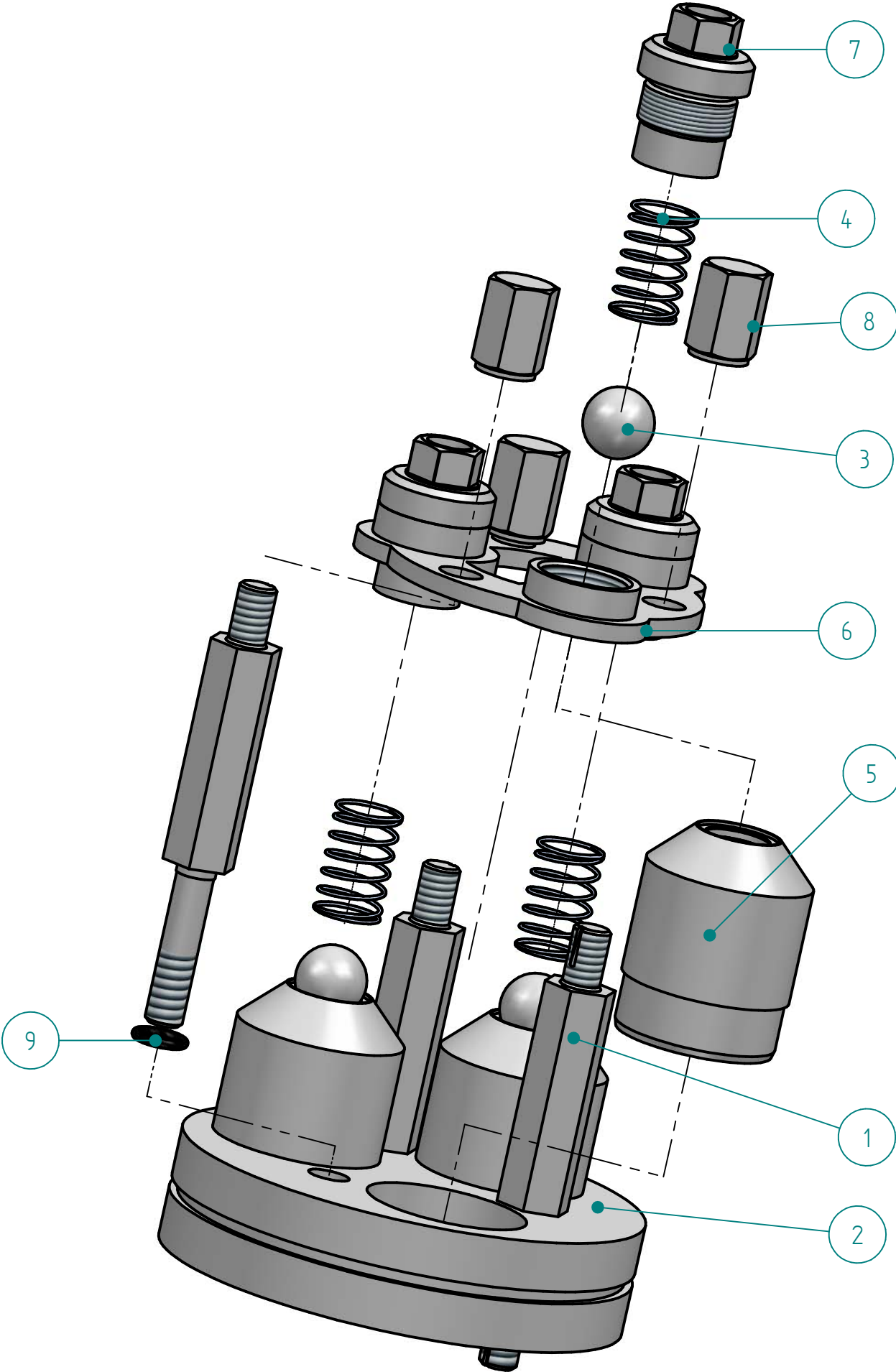
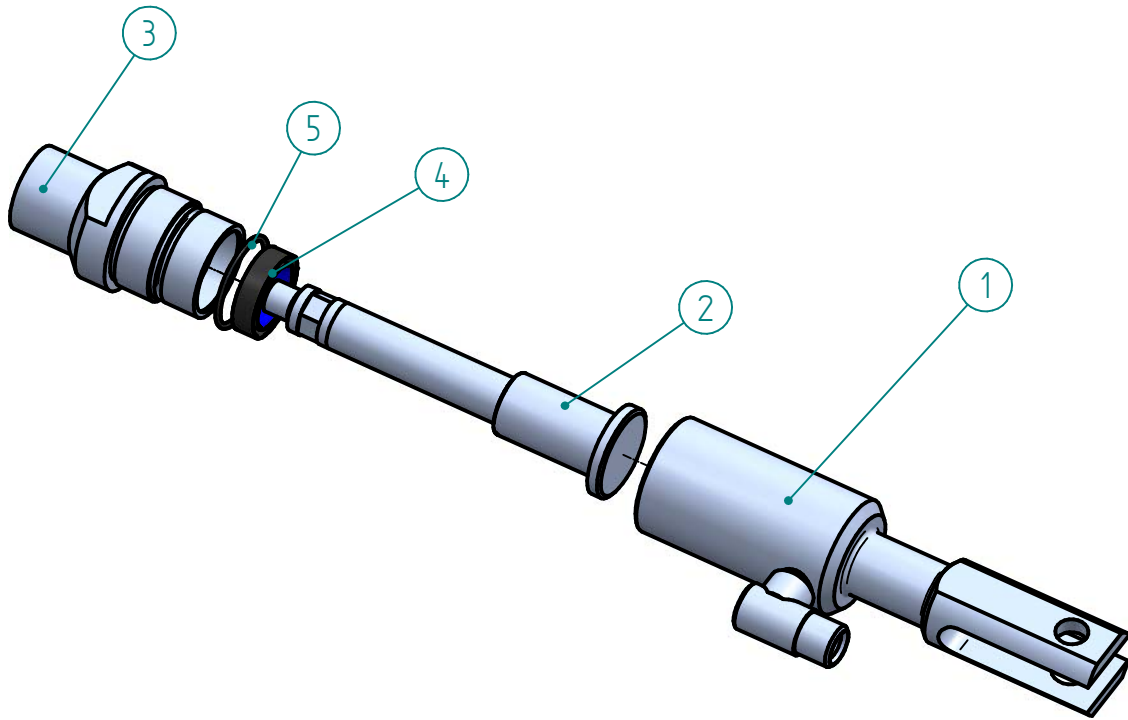

FIGURE 4 (Passport I)







Item no	Part no	Description	Quantity
1	10242	Cylinder housing	1
2	10243	Piston	1
3	10244	Sleeve	1
4	10246	Collar sealing	1
5	10247	O-ring	1

FIGURE 8 (Passport I)

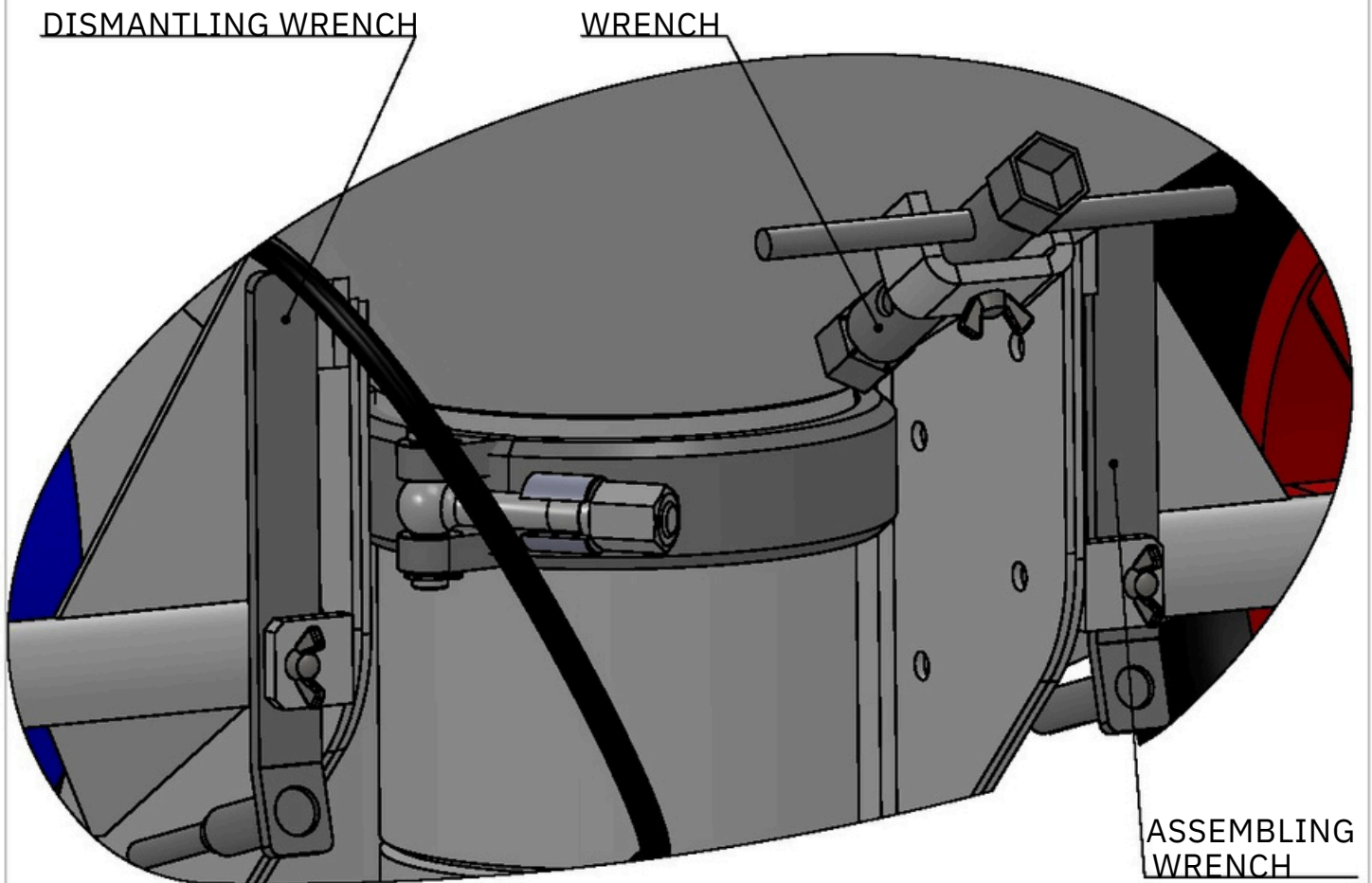

FIGURE 9 (Passport I)

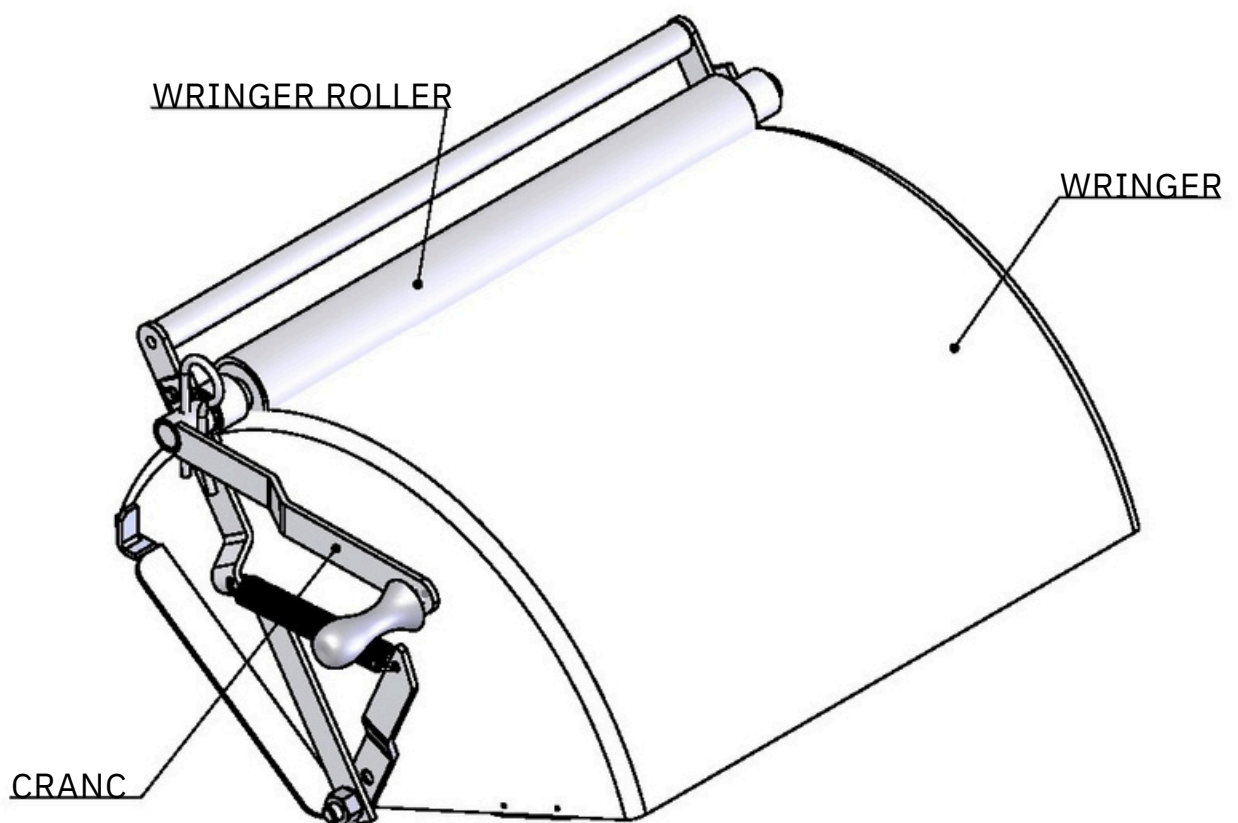

FIGURE 1 (Passport II)

Item	Article number	Name	Quantity
1	10600	Chassis	1
2		Pump	1
3		Hydraulic system	1
4		Power transmission	1
5	10416	Electrical unit	1
6	10611K	Bag wringer	1
7	SP25000	Spray gun	1
8	10910	Hose	1
9	10609	Chain wheel protector	1
10	10610	Nose	1
11	10604	Handle	1
12	10101	Dismantling wrench	1
13	10102	Assembling wrench	1
14	10123	Wrench	1
15	10601	Lock fittings	2
16	10602	Wheel	2
17	10606	Rubber handle	2
18	10607	Rubber support	2

FIGURE 1 (Passport II)

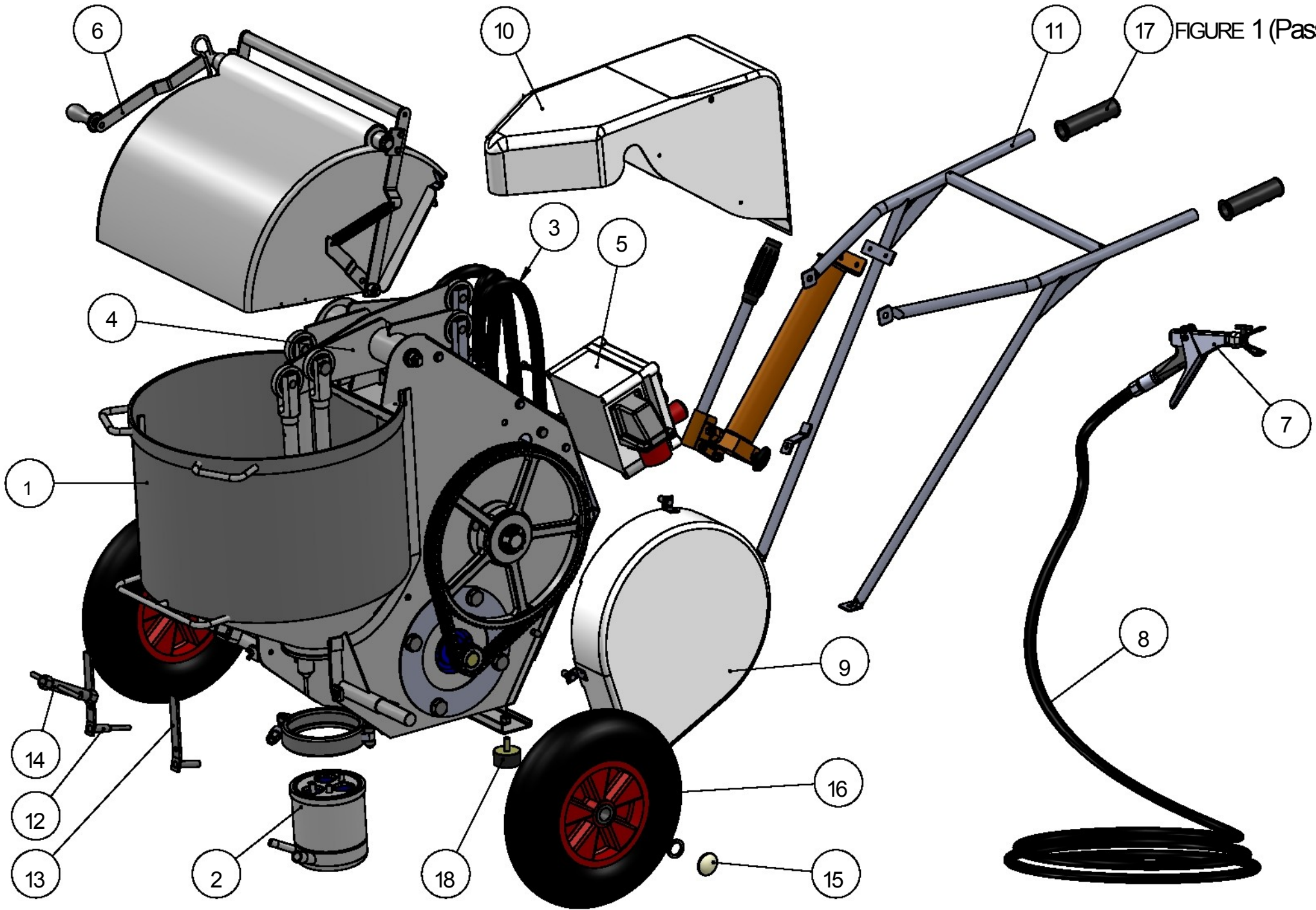

FIGURE 2 (Passport II)

Item	Article number	Name	Quantity
1	10103	Bottom plug	1
2	10103P	Packing	1
3	10104	Pressure vessel	1
4	10105	Holding bolt	1
5	10106	Filter clip	1
6	10107	Filter	1
7	10108	Filter holder	1
8	10110	Space bolt	3
9	10113	Valve base	1
10	10115	Support ring	3
11	10246	Collar seal	3
12	10117	O-ring	2
13	10121	Tension ring	1
14	10122	Space bolt o-ring	3
15	10126	Valve ball	3
16	10127	Valve spring	3
17	10128	Valve	3
18	10129	Valve body	3

FIGURE 2 (Passport II)

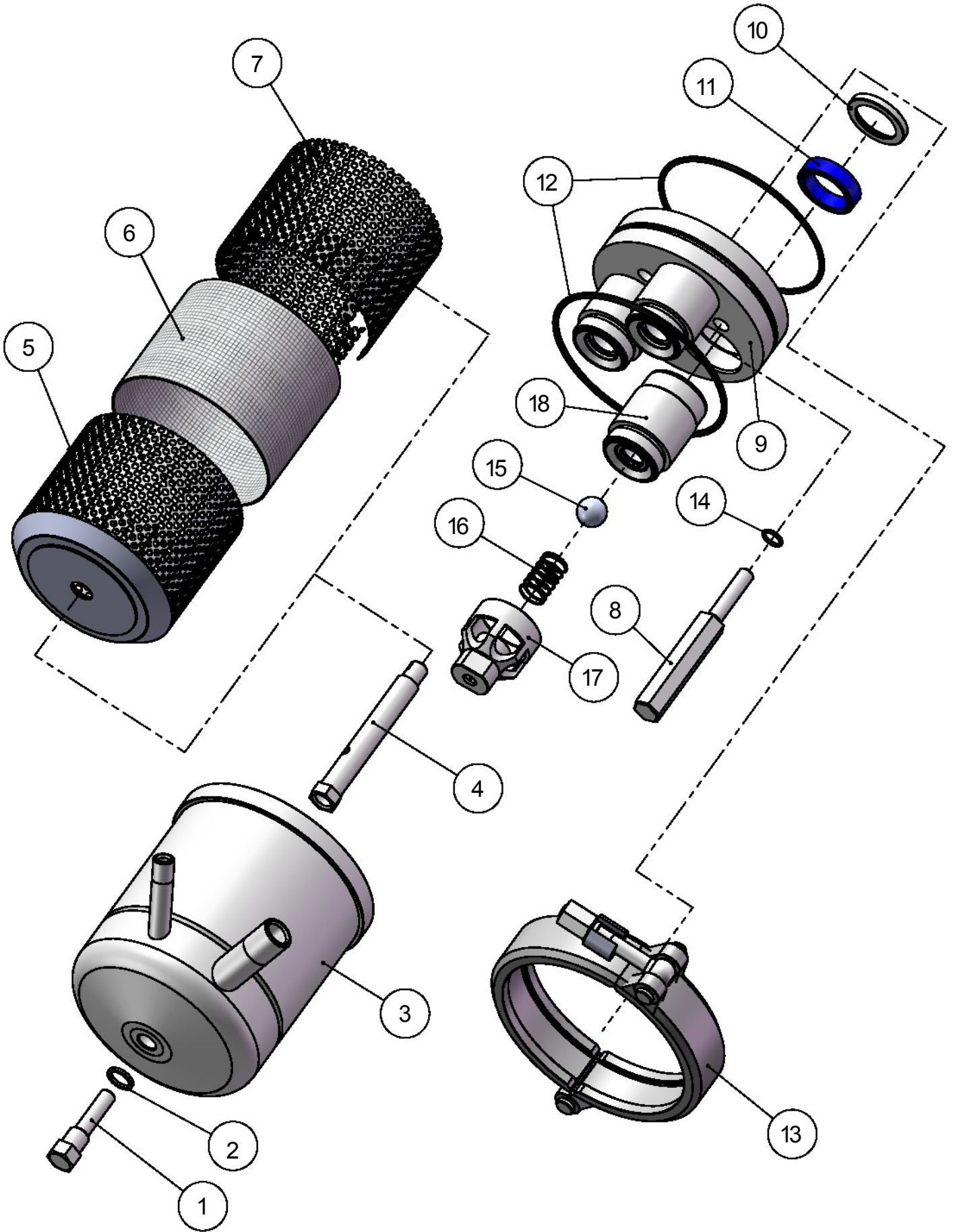
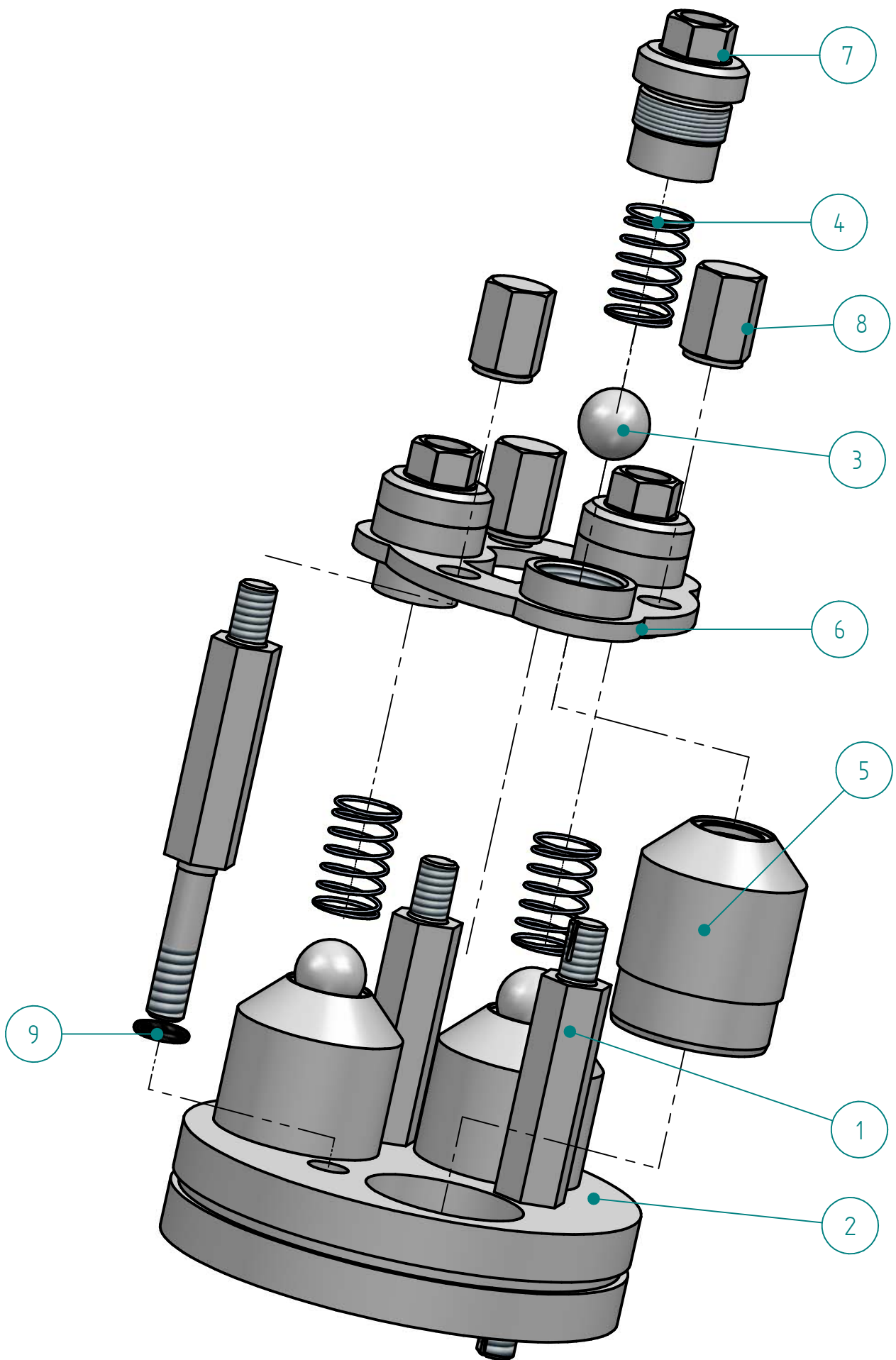
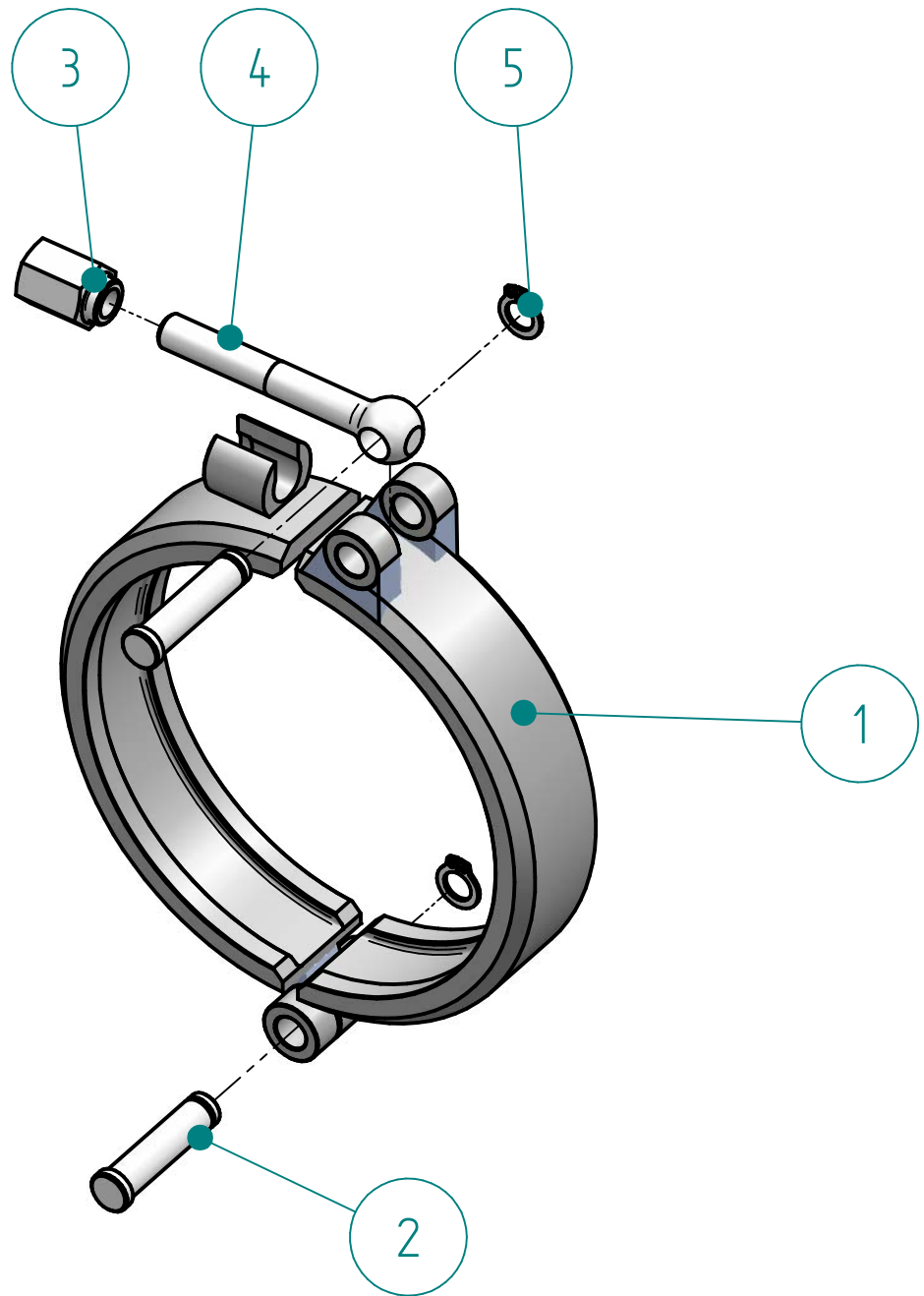

Figure 3 (Passport II)

Stainless steel pump unit

Item no	Part no	Description	Quantity
1	10110SST	Space bolt	3
2	10113SST	Valve base	1
3	10126	Valve ball	3
4	10127	Valve spring	3
5	10129SST	Valve body	3
6	10130SST	Plate	1
7	10133SST	Spring holder	3
8	10134SST	Nut	3
9	10122	Space bolt o-ring	3





Item no	Part no	Description	Quantity
1	10121.01	Ring	1
1	10121.03	Eye bolt	2
3	10121.04	Nut	1
4	10121.06	Bolt	1
5	10121.07	Fixing ring	2

FIGURE 5 (Passport II)

Hydraulic system

Item	Article number	Name	Quantity
1	10201	Handpump	1
2	10201A	Handpump connection	1
3	10232	Connection hose ½ ” long	2
4	10232-1	Connection hose ½ ” short	1
5	10235	Manifold pipe	1
6	10235-1	Plug	1
7	10235-2	Seal	1
8	10240	Hydrocilinder	3
9	10249	Hydraulic accumulator	1
10	10253	Manometer	1
11	10253-1	Manometer coupling	1
12	10253-2	Packing	1
13	10253-3	Threeway	1
14	10257	Adapter ½v-¼v	1
15	10257A	Adapter ½v-½s	1
16	10258	Adapter ½v-½v	3
17	10259	Connector pipe	1
18	10260	Hydraulic accumulator hose	2

Figure 5 (Passport 2)

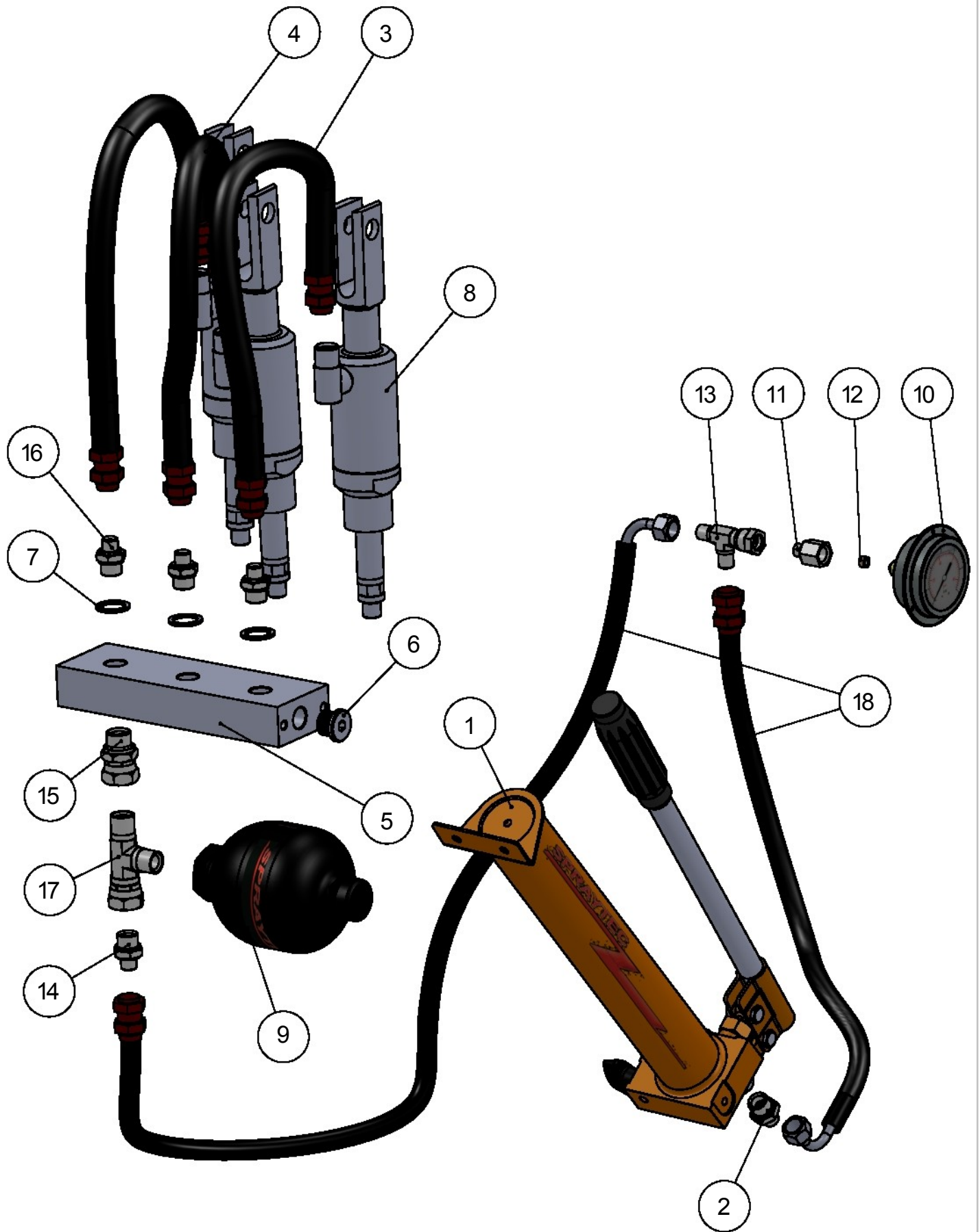

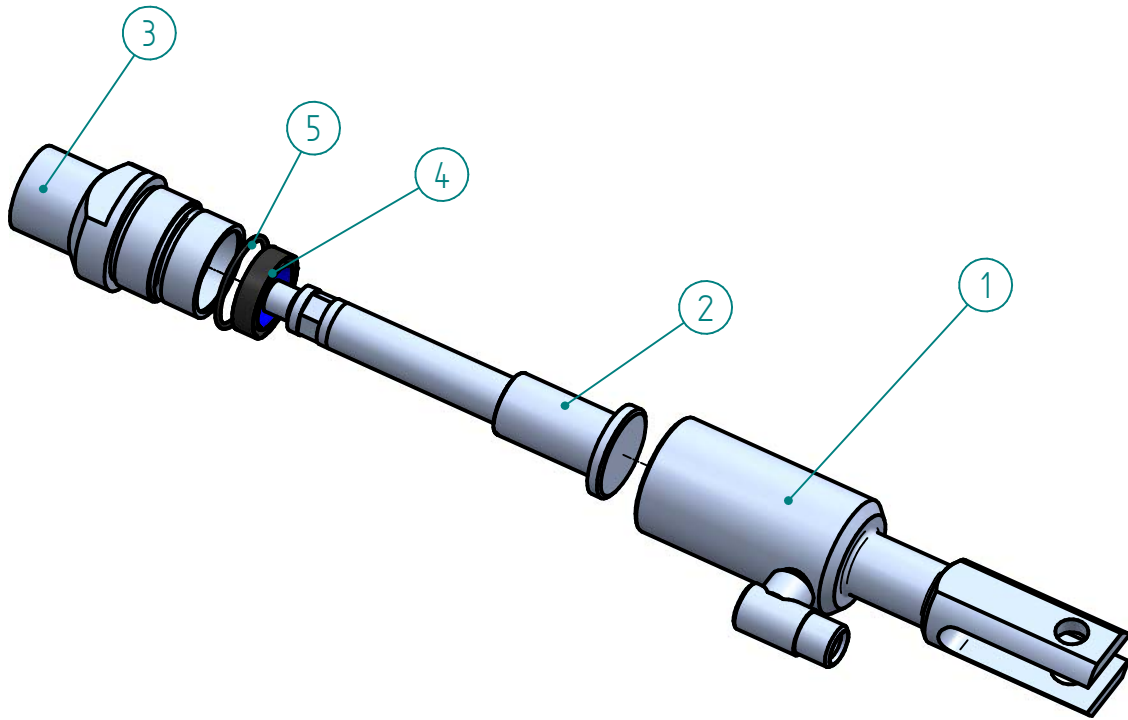

Item no	Part no	Description	Quantity
1	10242	Cylinder housing	1
2	10243	Piston	1
3	10244	Sleeve	1
4	10246	Collar sealing	1
5	10247	O-ring	1

Figure 7 (Passport II)

Power transmission

Pos.	Det. No	Name	Quantity
1	10114	pump piston	3
2	10240	hydraulic cylinder	3
3	10248	joint bolt	6
4	10301	crancshaft	1
5	10302	bearing	3
6	10303	bearing ring	3
7	10304	bearing	2
8	10307	chainwheel	1
9	10308	chain	1
	10309	locking link	1
10	10310	motor sprocket	1
11	10313K	outside rocket	2
12	10314K	middle rocket	1
13	10316	rocket axel	1
14	10317	nut M16	2
15	10318	washer	2
16	10321	middle pump rod	1
17	10321A	outer pump rod	2
18	10323	coupling	1
19	10401	motor	1
20	10613	fixing plate	1
21	103032	fixing ring SGH 125	3
22	103033	fixing ring SGA 30	2
23	10330	fixing ring SGA 80	4
24	10403	fixing bolt	4

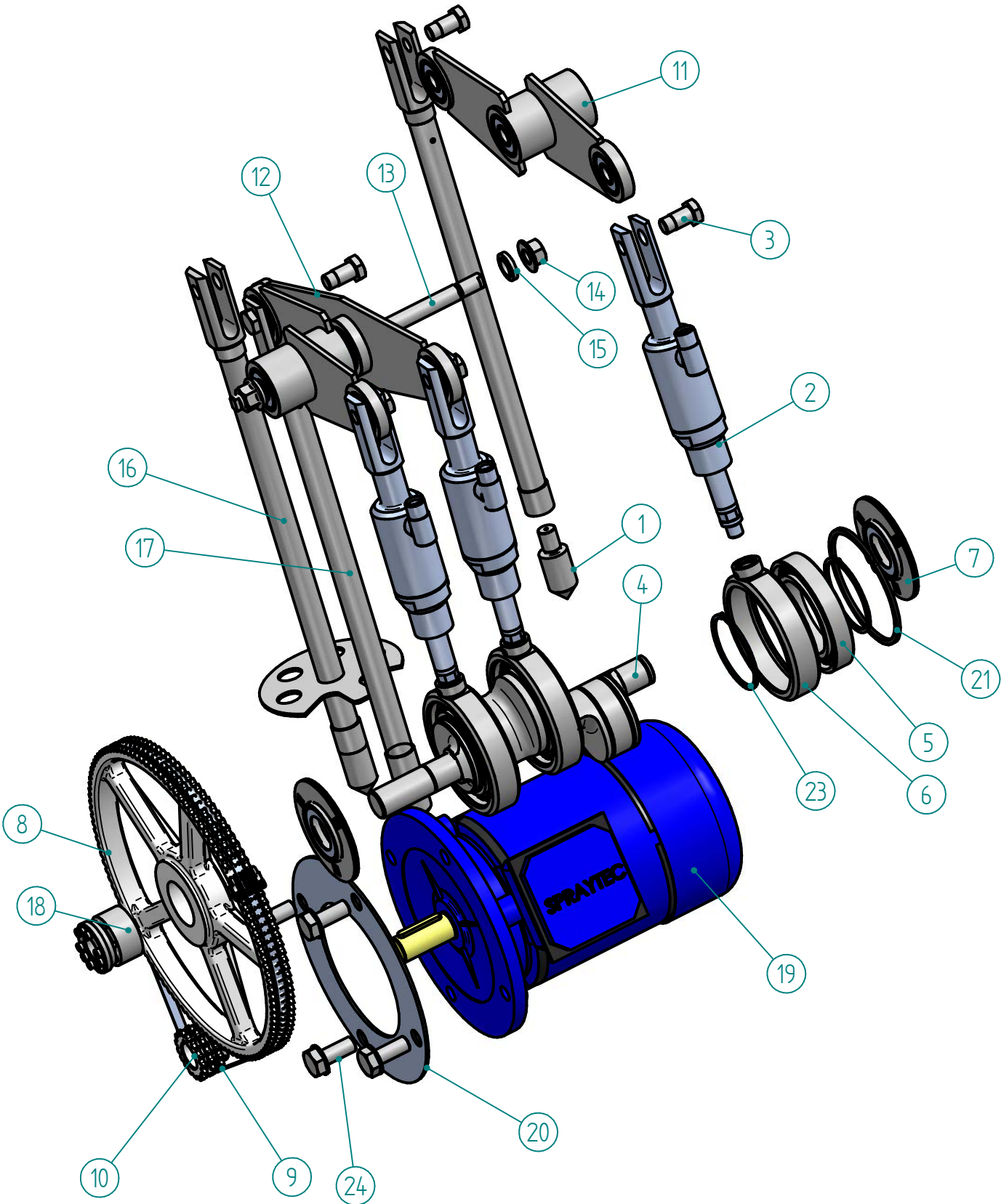

Outside rocker 10313K

FIGURE 8 (Passport II)

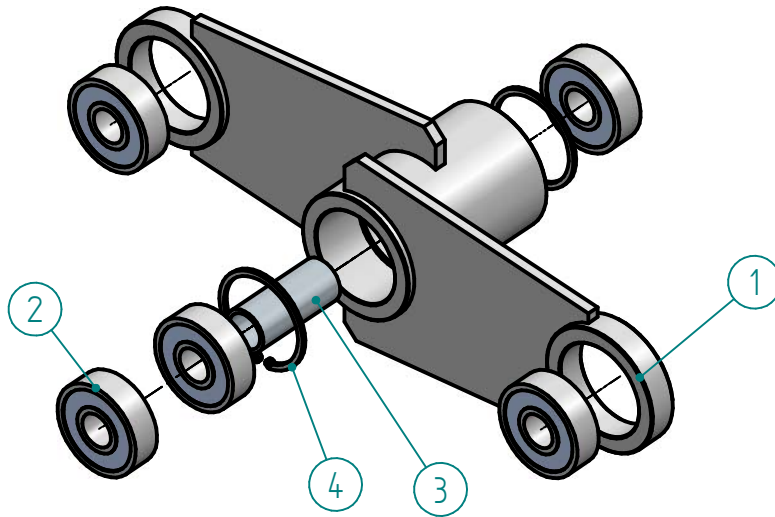

Item no	Part no	Description	Quantity
1	10313	Outside rocker	1
2	10315	Bearing	5
3	10319	Spacer sleeve	1
4	103131	Fixing ring	2

Middle rocker 10314K

FIGURE 9 (Passport II)

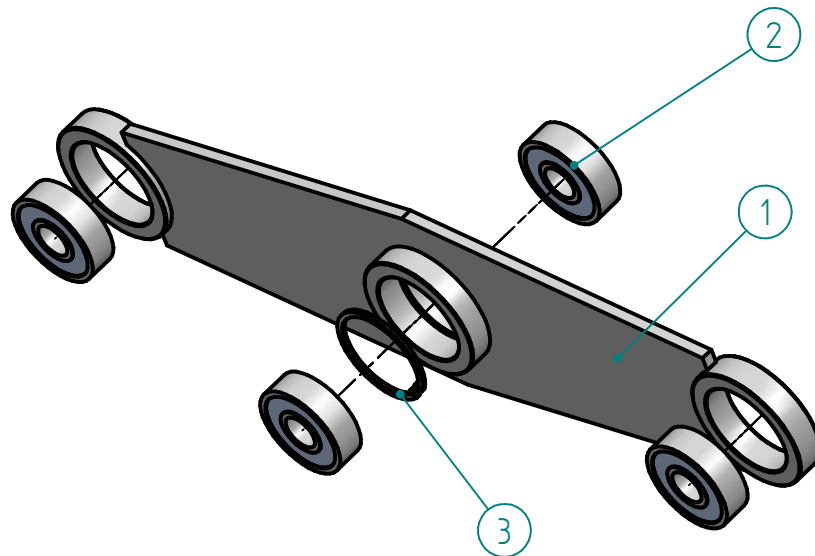

Item no	Part no	Description	Quantity
1	10314	Middle rocker	1
2	10315	Bearing	4
3	103131	Fixing ring	1

FIGURE 10 (Passport II)

Electrical unit

Item	Article number	Name	Quantity
1	10416	Electrical unit	1
2	10450	Pressure sensor	1
3	10451	Pressure sensor connection	1
4	10452	Washer	1
5	10453	Pressure sensor hose	1

Figure 10 (Passport II)

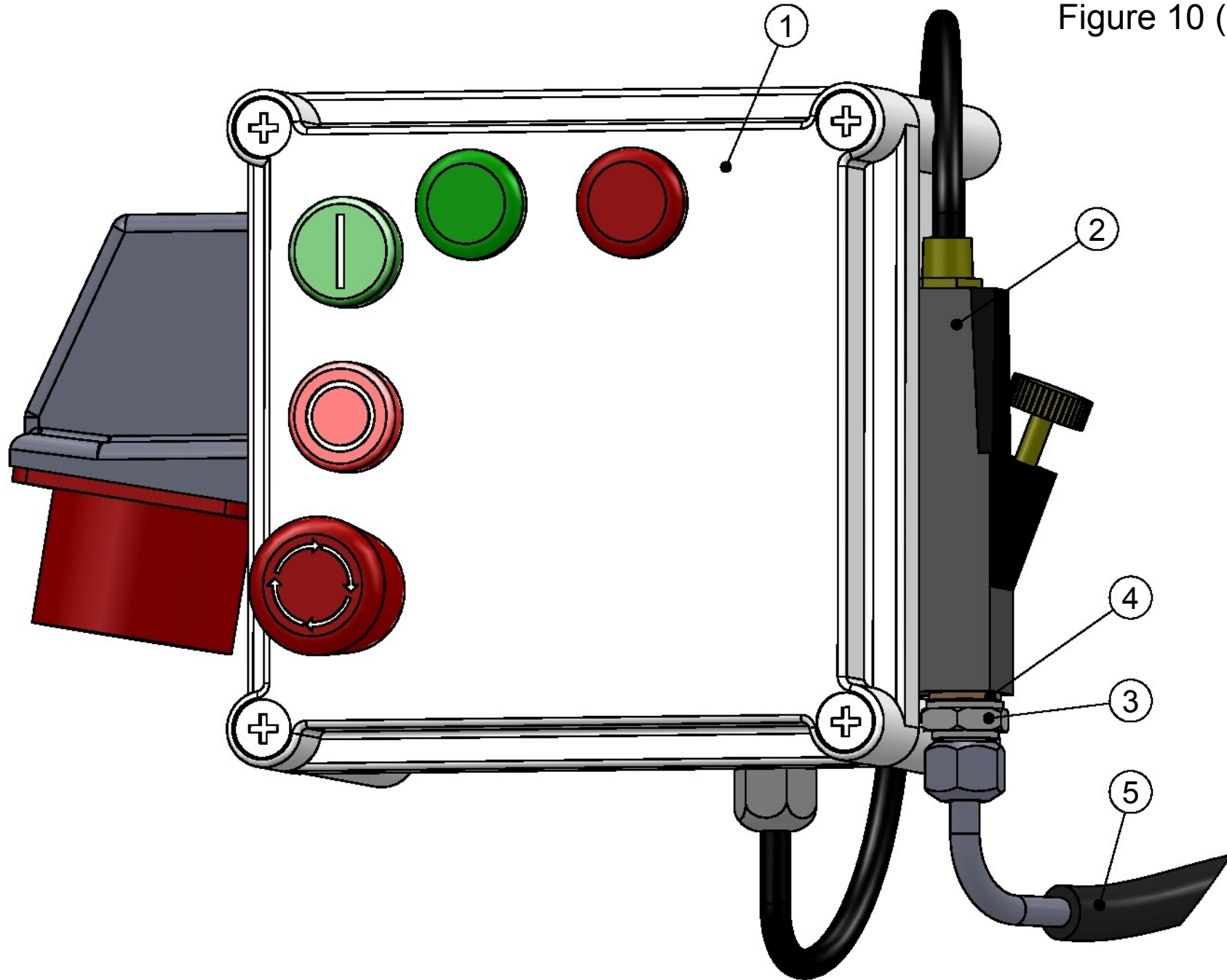

handle

FIGURE 11 (Passport II)

Bag wringer 10611K

Item	Article number	Name	Quantity
1	10611	Bag wringer	1
2	10612A	Cranc	1
3	10612B	Handle	1
4	10614	Fastener	2
5	10615	Fastener plate	1
6	10616	Spring	2
7	10622	Cranc fixator	1
8	10625A	Bag wringer frame	1
9	10625B	Left spring brace	1
10	10625C	Right spring brace	1
11	10627	Bushing and bushing holder	2
	10627.01	Bush	2
	10627.02	Holder	2
12	10628	Roller	1

Figure 11 (Passport II)

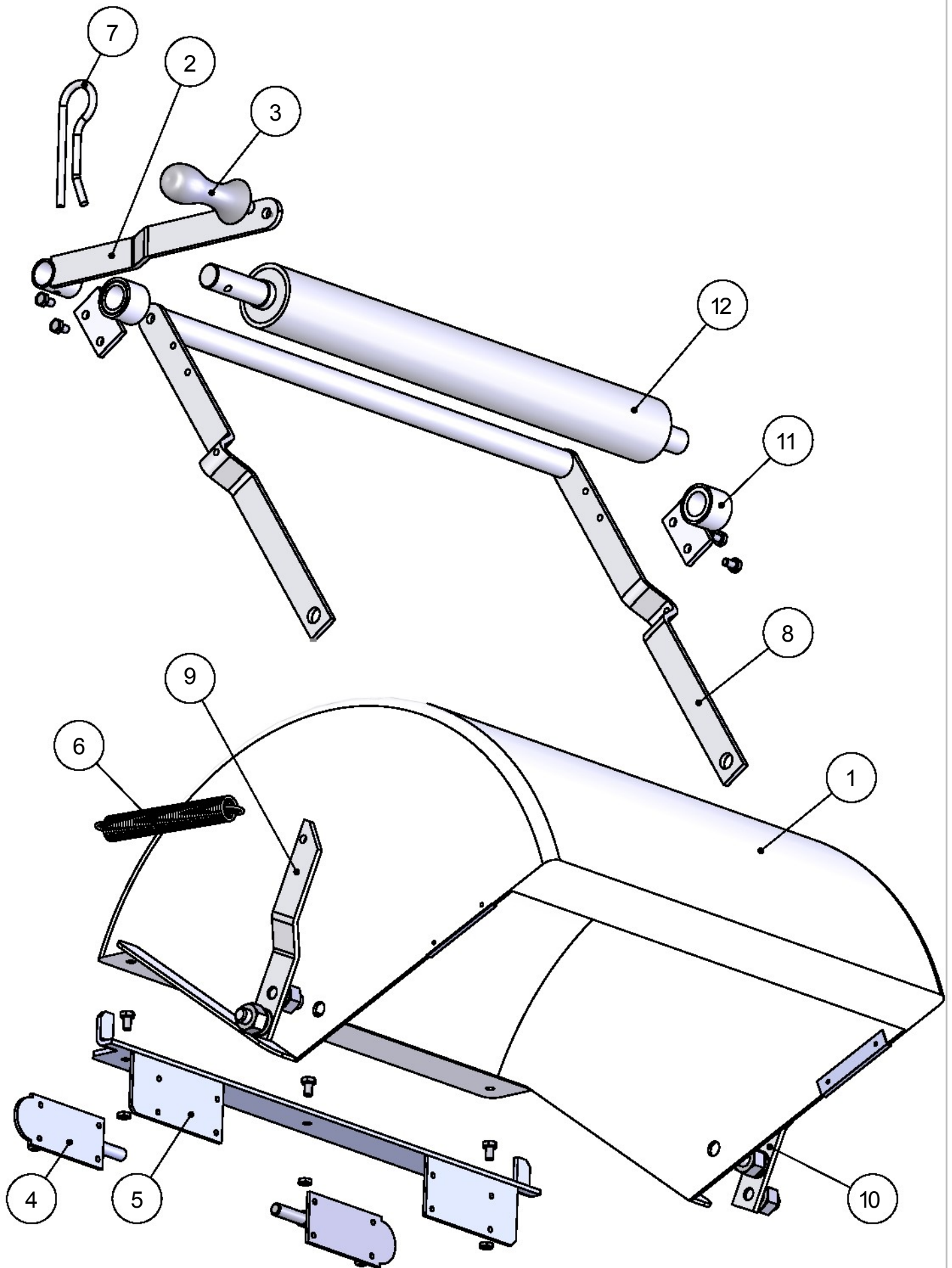

FIGURE 12 (Passport II)

Spray gun SPR25000

Item	Article name	Name	Quantity
1	25001	Body	1
2	25002	Valve seat	1
3	25003	Needle	1
4	25004	Bush	1
5	25005	Mutter	1
6	25006	Packing	1
7	25007	Pusher	1
8	25008	Support ring	1
9	25009	Spring	1
10	25010	Cap nut	1
11	25011	Packing ring	1
12	25012	Tube	1
13	25013	Handle	1
14	25014	Trigger	1
15	25015	Axle	2
16	25016	Locking	1
17	25017	Fixing ring	2
18	25018	Screw	1
19	25019	Ring	1
20	25020	Packing	1
21	25100	Swivel	1
22	25022	Washer	2
23	25023	Washer	2
24	15800	Tip holder	1
25	12xxx	Tip	1

Figure 12 (Passport II)

